



To: Planning Committee

Date: May 6, 2016

From: Wayne Craig
Director, Development

File: RZ 16-721609

Re: **Application by Paul Atwal for Rezoning at 7651 Bridge Street from Single Detached (RS1/F) to Single Detached (ZS14) - South McLennan (City Centre)**

Staff Recommendation

That Richmond Zoning Bylaw 8500, Amendment Bylaw 9561, for the rezoning of the west portion of 7651 Bridge Street from “Single Detached (RS1/F)” to “Single Detached (ZS14) - South McLennan (City Centre)”, be introduced and given first reading.

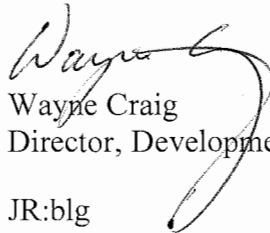

Wayne Craig
Director, Development

JR:blg
Att.

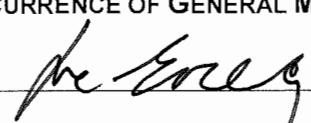
REPORT CONCURRENCE		
ROUTED TO:	CONCURRENCE	CONCURRENCE OF GENERAL MANAGER
Affordable Housing	<input checked="" type="checkbox"/>	

Staff Report

Item	Details		
Applicant	Paul Atwal		
Location	See Attachment 1		
Development Data Sheet	See Attachment 2		
Zoning	Existing: Single Detached (RS1/F)		
	Proposed Lot 1: Single Detached (RS1/F) Proposed Lot 2: Single Detached (ZS14) – South McLennan (City Centre) See Attachment 3		
OCP Designation	Neighbourhood Residential	Complies:	Yes
Area Plan Designation	Residential, historic single-family	Complies:	Yes
Surrounding Development	North: Single-family dwellings on small lots in the “Single Detached (ZS14) – South McLennan (City Centre)” zone fronting Armstrong Street, and one (1) single-family dwelling on a lot in the “Single Detached (RS1/F)” zone fronting Bridge Street.		
	South: One single-family dwelling in the “Single Detached (RS1/F)” zone with a development application to rezone and subdivide (RZ 16-728740).		
	East: Single-family dwellings across Bridge Street on deep lots in the “Single Family (RS1/F)” zone.		
	West: Single-family dwellings across Armstrong Street on small lots in the “Single Detached (ZS14)” zone fronting Keefer Avenue.		
Rezoning Considerations	See Attachment 8		

Floodplain Management Implementation Strategy

The proposed redevelopment must meet the requirements of the Richmond Flood Plain Designation and Protection Bylaw 8204. Registration of a flood indemnity covenant on Title is required prior to final adoption of the rezoning bylaw.

Public Consultation

Rezoning signs have been installed on both street frontages of the subject property. Staff have not received any comments from the public about the rezoning application in response to the placement of the rezoning signs on the property.

Should the Planning Committee endorse this application and Council grant first reading to the rezoning bylaw, the bylaw will be forwarded to a Public Hearing where any area resident or interested party will have an opportunity to comment.

Analysis

The proposed rezoning would enable subdivision of the subject property into two (2) lots, one (1) zoned “Single Detached (RS1/F)” fronting Bridge Street, and one (1) zoned “Single Detached (ZS14) – South McLennan (City Centre)” fronting Armstrong Street. A survey showing the proposed subdivision plan is provided in Attachment 3. There is an existing single-family dwelling on the proposed east lot of the subject site that will be retained. The principal structure and accessory structures to be retained comply with the requirements of the proposed “Single Detached (RS1/F)” zoning bylaw, including setbacks, lot coverage, and density (Attachment 4).

Proposed Site Access

Vehicle access to Lot 1 will be retained on Bridge Street. Lot 2 will be accessed from Armstrong Street. The City has requested road dedication for an extension of this street as part of the improvements to the neighbourhood circulation network as per the McLennan South Sub-Area Plan (Attachment 5). The road dedication will start at 9.0 m at the northwest corner and taper to 7.5 m at the southwest corner, for a total area of 158.4 m².

Affordable Housing Strategy

As per the City’s Affordable Housing Strategy, single-family rezoning applications require a secondary suite or coach house on 100% of new lots created, or a combination of secondary suites or coach houses on 50% of new lots and a \$2.00/ft² cash-in-lieu contribution of the total buildable area of the remaining lots to the City’s Affordable Housing Reserve Fund.

The applicant proposes to provide a secondary suite on Lot 2. The existing dwelling to be retained on Lot 1 has an existing secondary suite. To ensure that the secondary suite on Lot 2 is built to the satisfaction of the City and in accordance with the City’s Affordable Housing Strategy, the applicant is required to enter into a legal agreement registered on Title stating that no final Building Permit inspection will be granted until the secondary suite is constructed to the satisfaction of the City in accordance with the BC Building Code and the City’s Zoning Bylaw. Registration of this legal agreement is required prior to final adoption of the zoning bylaw.

Tree Retention and Replacement

The applicant submitted a Certified Arborist’s Report, which identifies on-site and off-site tree species, assesses their structure and condition, and provides recommendations on tree retention and removal relative to the proposed development. The Report assesses four (4) bylaw-sized trees on the subject site (Trees # 1-4) and one (1) Douglas fir tree (Tree # 5) on City-owned property to the northeast of the subject site on Bridge Street.

The City’s Tree Preservation Coordinator and the City’s Parks Department staff have reviewed the Arborist’s Report, conducted visual tree assessment, and provide the following comments:

- The Douglas Fir (Tree # 5) located on City property is to be retained. Retained trees should be protected as per City of Richmond Tree Protection Information Bulletin Tree-03.

- One (1) tree (Tree # 1) is a 35cm caliper Cherry; previously topped and in poor condition. A Tree Permit (TP15-716474) was issued for the removal of this tree prior to rezoning application submission. This tree should be removed and replaced due to its poor condition.
- Three (3) trees (Trees # 2, 3 and 4) are identified to be retained and protected. Tree protection is to be provided as per City of Richmond Tree Protection Information Bulletin Tree-03.
- Replacement trees at 2:1 ratio as per the Official Community Plan (OCP) will be required of the trees to be removed.

Tree Protection

The applicant proposes to retain three (3) of the bylaw-sized trees on the property (Attachment 7). These are Trees #2-#4; all of which are located within the rear yard of proposed Lot 1. As no construction or landscaping is proposed on this lot, the applicant proposes to erect a protective fence along the new property line before construction begins and for the duration of the project.

Tree Replacement

The ZS14 zone in Zoning Bylaw 8500 requires the applicant to plant and maintain three (3) trees on each lot, with at least one (1) of these trees located within 6 m of the front lot line. There are no existing trees on Lot 2; therefore three (3) trees must be provided on this lot. Prior to final adoption of the rezoning bylaw, the applicant must submit a Landscaping Security for all three (3) trees in the amount of \$1,500 (\$500/tree) to ensure that the trees are planted and maintained.

Site Servicing and Frontage Improvements

Road dedication is required to provide access from Armstrong Street to the site starting at 9.0 m at the northwest corner; tapering to 7.5 m at the southwest corner.

The applicant is required to make a separate application for a Servicing Agreement for the following:

- Undergrounding of hydro, telephone, and cable connections for both lots.
- Improvements on Armstrong Street including road and sidewalk construction
- Improvements on Bridge Street including road widening and sidewalk construction

Details on the rezoning considerations are outlined in Attachment 8.

Financial Impact or Economic Impact

This rezoning application results in an insignificant Operational Budget Impact (OBI) for off-site City infrastructure.

Conclusion

This purpose of this rezoning application is to rezone the west portion of 7651 Bridge Street from the "Single Detached (RS1/F)" zone to the "Single Detached (ZS14) - South McLennan

(City Centre)" zone, to permit the property to be subdivided to create two (2) lots; one (1) fronting Bridge Street and one (1) fronting Armstrong Street.

This rezoning application complies with the land use designations and applicable policies for the subject site contained in the OCP and zoning bylaw.

The list of rezoning considerations is included in Attachment 8; which has been agreed to by the applicant (signed concurrence on file).

It is recommended that Zoning Bylaw 8500, Amendment Bylaw 9561 be introduced and given first reading.

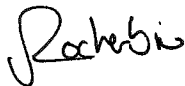

Jordan Rockerbie
Planning Technician
(604-276-4092)

JR:blg

- Attachment 1: Location Map and Aerial Photo
- Attachment 2: Development Application Data Sheet
- Attachment 3: Survey showing proposed subdivision
- Attachment 4: Survey showing proposed Lot 1
- Attachment 5: McLennan South Neighbourhood Circulation Map
- Attachment 6: McLennan South Land Use Map
- Attachment 7: Tree Retention Plan
- Attachment 8: Rezoning Considerations



City of
Richmond

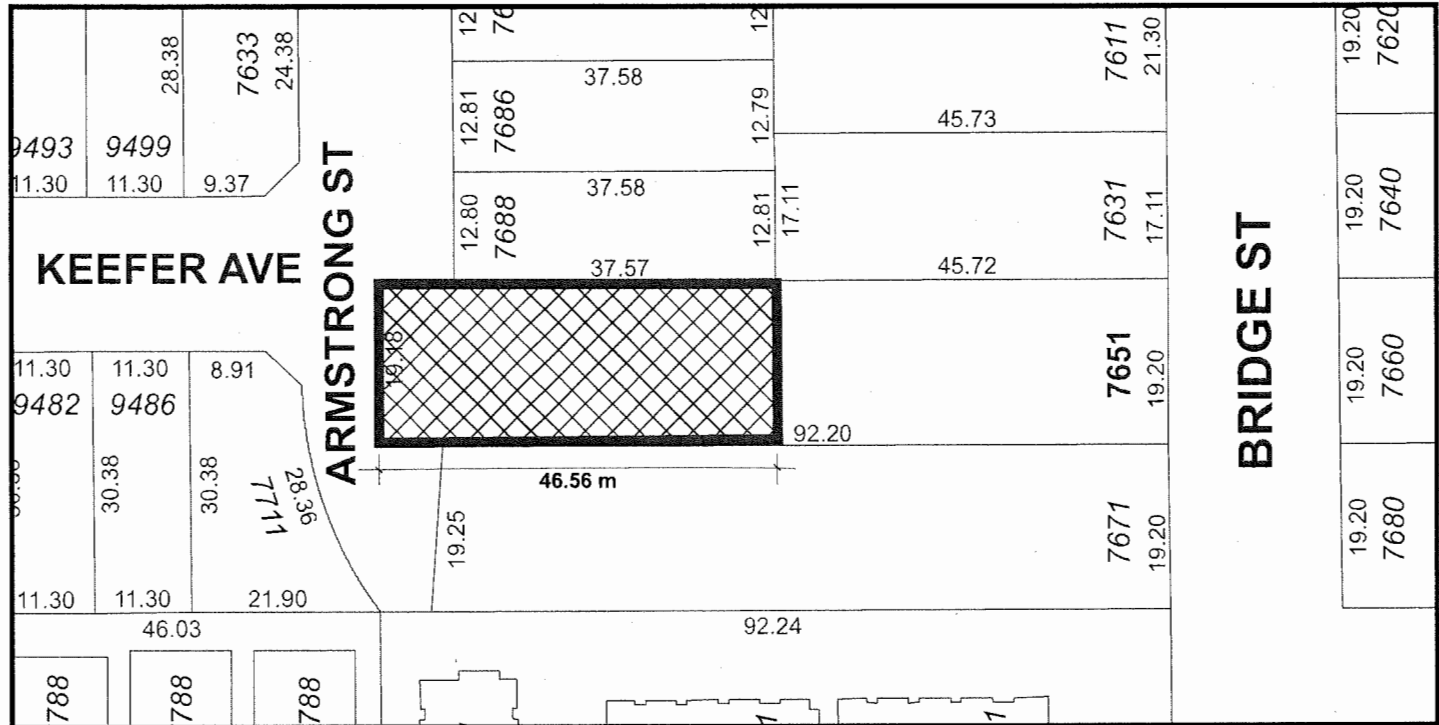
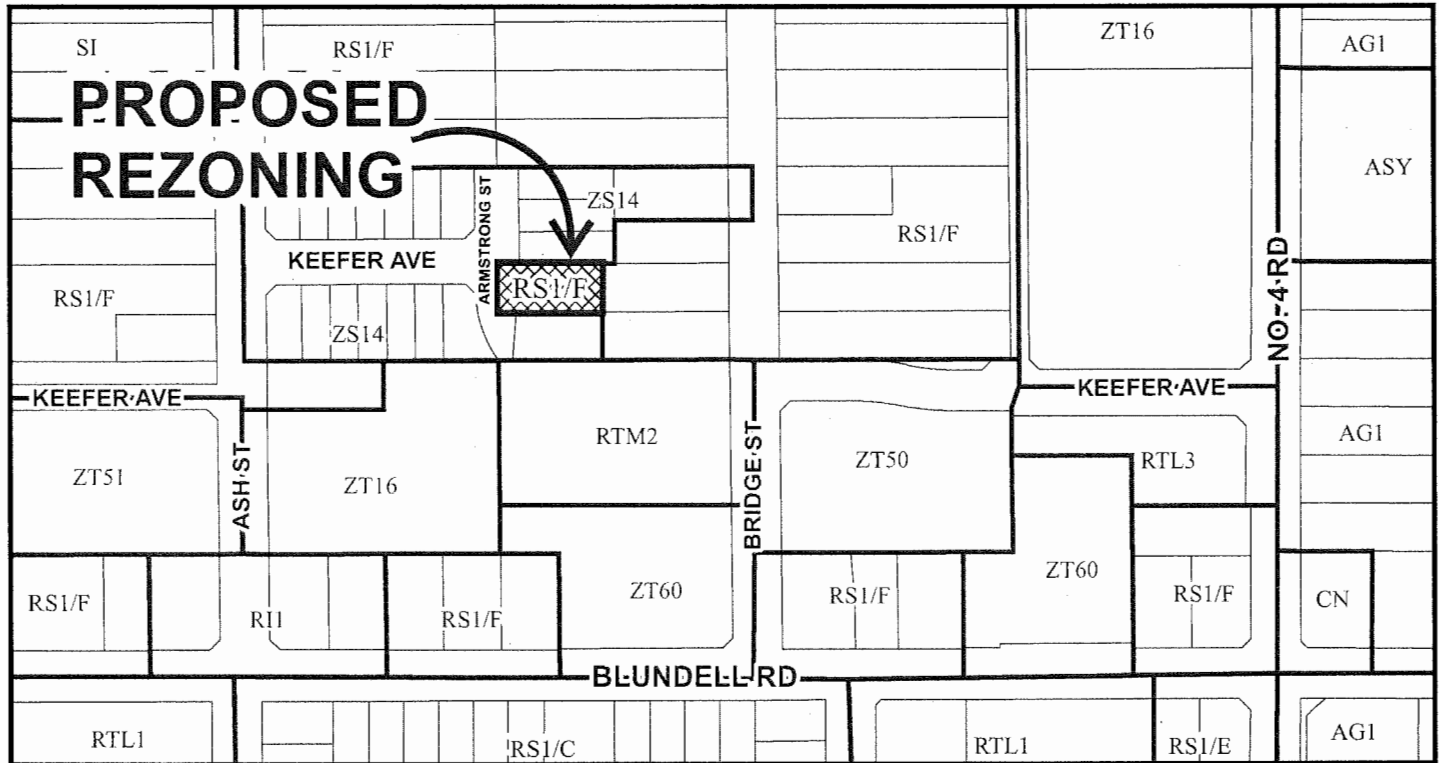

	<h1>RZ 16-721609</h1> <p>PLN - 308</p>	<p>Original Date: 03/01/16 Revision Date: 04/29/16 Note: Dimensions are in METRES</p>
--	--	---



City of
Richmond



RZ 16-721609

Original Date: 03/01/16

Revision Date: 04/04/16

Note: Dimensions are in METRES

PLN - 309



RZ 16-721609

Attachment 2

Address: 7651 Bridge Street

Applicant: Paul Atwal

Planning Area(s): City Centre – McLennan South Sub-Area

	Existing	Proposed
Owner	Glicerio Ganuelas Consolacion Ganuelas	To be determined
Site Size (m²)	1,612.7 m ²	Lot 1: 877.4 m ² Lot 2: 735.3 m ²
Land Uses	One (1) single-family dwelling	One (1) single-family dwelling on each of two (2) lots
OCP Designation	Neighbourhood Residential	No change
Area Plan Designation	Residential, Historic Single-Family	No change
Zoning	Single Detached (RS1/F)	Lot 1: No change Lot 2: Single Detached (ZS14) – South McLennan (City Centre)

On Future Subdivided Lot 1	Bylaw Requirement Single Detached (RS1/F)	Proposed	Variance
Floor Area Ratio	Max. 0.55 applied to the first 464.5 m ² of the lot area, together with 0.30 applied to the balance of the lot area	Max. 0.55 applied to the first 464.5 m ² of the lot area, together with 0.30 applied to the balance of the lot area	none permitted
Lot Coverage – Building	Max. 45%	18.7%	none
Lot Coverage – Impermeable Surfaces	Max. 70%	Max. 70%	none
Lot Coverage – Live Plant Material	Min. 25%	Min. 25%	none
Lot Size	Min. 828 m ²	877.4 m ²	none
Setback – Front Yard (m)	Min. 6.0 m	10.33 m	none
Setback – Rear Yard (m)	Min. 6.0 m	23.14 m	none
Setback – Side Yard (North) (m)	Min. 1.8 m	3.44 m	none
Setback – Side Yard (South) (m)	Min. 1.8 m	1.83 m	none
Height	2 ½ Storeys	2 ½ Storeys	none

On Future Subdivided Lot 2	Bylaw Requirement Single Detached (ZS14)	Proposed	Variance
Floor Area Ratio	Max. 0.55 applied to the first 464.5 m ² of the lot area, together with 0.30 applied to the balance of the lot area	Max. 0.55 applied to the first 464.5 m ² of the lot area, together with 0.30 applied to the balance of the lot area	none permitted
Lot Coverage – Building	Max. 45%	Max. 45%	none
Lot Coverage – Impermeable Surfaces	Max. 70%	Max. 70%	none
Lot Coverage – Live Plant Material	Min. 25%	Min. 25%	none
Lot Size	Min. 320.0 m ²	735.3 m ²	none
Setback – Front & Rear Yards (m)	Min. 6.0 m	Min 6.0 m	none
Setback – Side Yard (m)	Min. 1.2 m	Min. 1.2 m	none
Height	2 ½ Storeys	2 ½ Storeys	none

Other: Tree replacement compensation required for loss of significant trees.

**SURVEY PLAN OF NORTH HALF LOT 14 BLOCK "F"
SECTION 15 BLOCK 4 NORTH RANGE 6 WEST
NEW WESTMINSTER DISTRICT PLAN 1207**

PARCEL IDENTIFIER (PID): 012-032-140

CIVIC ADDRESS
#7651 BRIDGE STREET
RICHMOND, B.C.

**TO ACCOMPANY RE-ZONING &
SUBDIVISION APPLICATION**

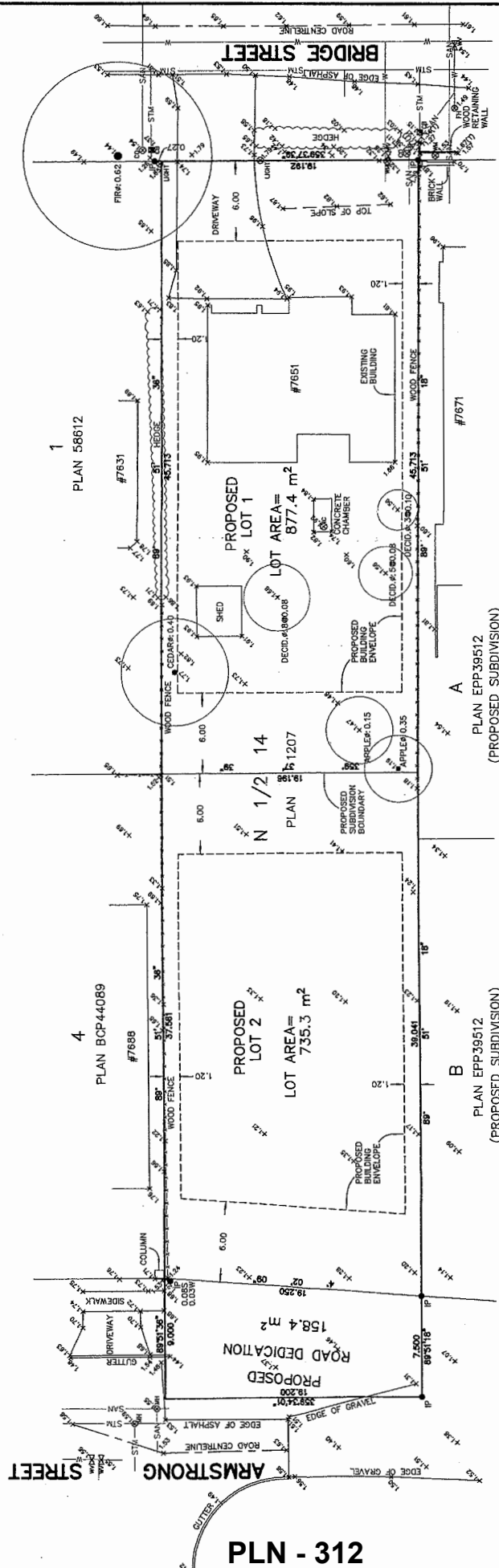
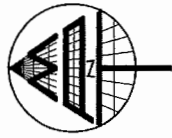

PLN - 312

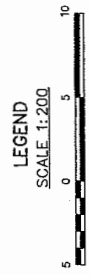

LEGEND
SCALE 1:200

- ALL DISTANCES ARE IN METRES
- INDICATES SPOT ELEVATION
 - CB INDICATES CATCH BASIN
 - CO INDICATES CLEAN OUT
 - FH INDICATES FIRE HYDRANT
 - IC INDICATES INSPECTION CHAMBER
 - MH INDICATES MANHOLE
 - WV INDICATES WATER VALVE
 - WA INDICATES WATER METER
 - (T) INDICATES TOP OF WALL
 - IP INDICATES IRON POST
 - SAN- INDICATES SANITARY LINE
 - STM- INDICATES STORM LINE
 - W- INDICATES WATER LINE

- NOTES:**
- PROPERTY LINE DIMENSIONS ARE DERIVED FROM LAND TITLE OFFICE PLAN RECORDS AND LEGAL FIELD SURVEYS.
 - ELEVATIONS ARE IN METRES AND ARE DERIVED FROM CITY OF RICHMOND TBM MEASUREMENT #202 (77H4623) WITH AN ELEVATION OF 1.962 METRES.
 - ALL DESIGNATED TREES AS DEFINED BY CITY OF RICHMOND (2010) ARE SHOWN ON THIS PLAN.
 - UNDERGROUND UTILITY LINES ARE FROM RICHMOND GIS AND HAVE NOT BEEN VERIFIED BY FIELD SURVEY.

© COPYRIGHT
MATSON PECK & TOPLISS
SURVEYORS & ENGINEERS
#230 - 11120 HORSESHOE WAY
RICHMOND, B.C. V7A 5H7
PR: 604-276-8331
FAX: 604-276-4137
CAD FILE: 18040-001-TP0-000.DWG

R-16-18040-TPC

DATE OF SURVEY: JANUARY 7, 2015

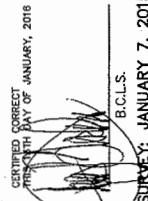

B.C.L.S.

**BRITISH COLUMBIA LAND SURVEYOR'S CERTIFICATE
OF LOCATION SHOWING BUILDING ON PART OF NORTH HALF LOT 14
BLOCK "F" SECTION 15 BLOCK 4 NORTH RANGE 6 WEST
NEW WESTMINSTER DISTRICT PLAN 1207**

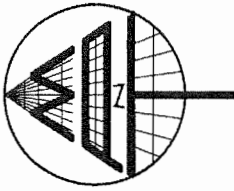

PROPOSED LOT 1

PARCEL IDENTIFIER (PID): 012-032-140

CIVIC ADDRESS
#7651 BRIDGE STREET
RICHMOND, B.C.

LEGEND

SCALE 1:150



ALL DISTANCES ARE IN METRES
DIMENSIONS ARE MEASURED
AT GRADE, TO VERTICAL FACE
OF BUILDING WALLS
UNLESS INDICATED OTHERWISE.

THE LINE REPRESENTING THE FACE
OF THE BUILDING WALL
DOES NOT INCLUDE EXTERNAL
BRICK WORK.

PLN - 313

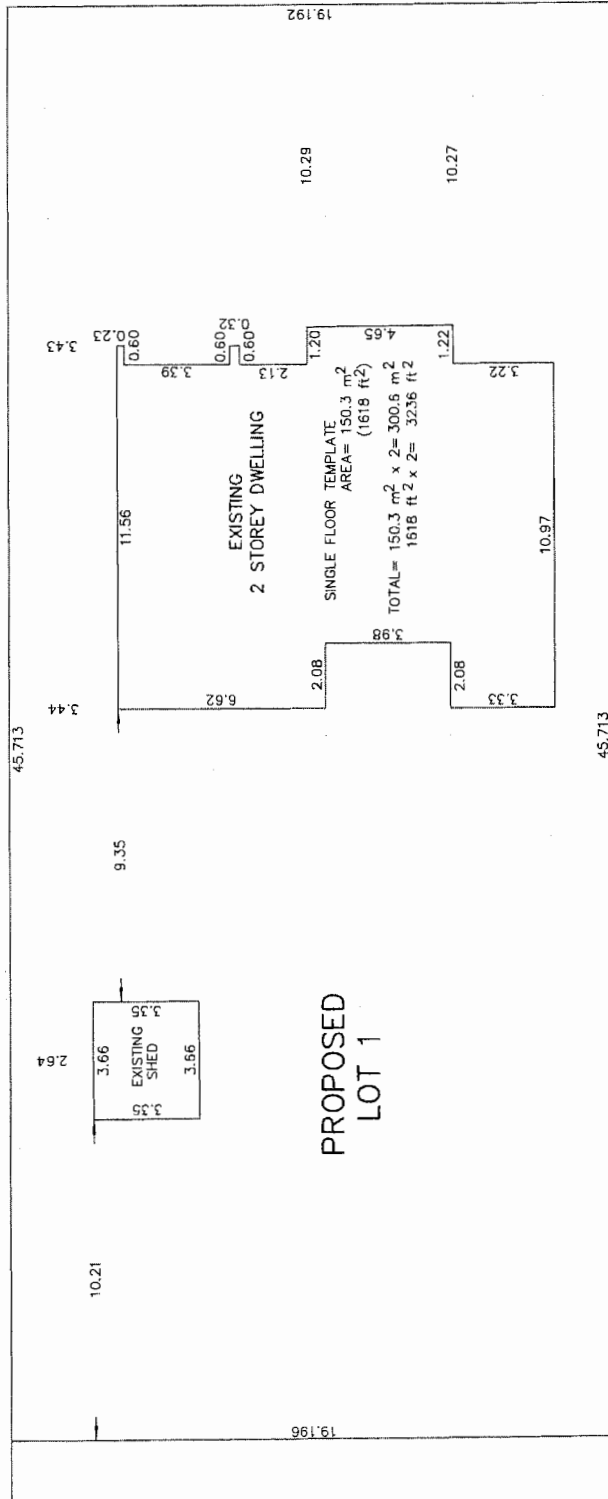

© COPYRIGHT

MATSON PECK & TOPLISS

SURVEYORS & ENGINEERS

#320 - 11120 HORSESHOE WAY
RICHMOND, B.C., V7A 5H7
PH: 604-270-9331
FAX: 604-270-4137

CADFILE: 18040-002-CERT-002.DWG

R-16-18040-CERT

THIS PLAN IS INTENDED ONLY TO SHOW THE POSITION OF
CERTAIN IMPROVEMENTS WITHIN THE SUBJECT PARCEL.
NO OTHER INFORMATION IS IMPLIED.
IN PARTICULAR THIS IS NOT TO BE USED FOR THE LOCATION
OF PROPERTY LINES OR FOR BUILDING MODIFICATIONS.
WE ACCEPT NO RESPONSIBILITY FOR ANY UNAUTHORIZED USE.

THIS CERTIFICATE IS VALID ONLY UNDER THE
ORIGINAL TERMS AND CONDITIONS OF OUR
CONTRACT WITH THE PARTY FOR WHICH IT WAS
PREPARED, AND AS SUCH ONLY ON THE DATE
CERTIFIED HEREON. SUBSEQUENT ADDITIONS AND
MODIFICATIONS TO TITLE, PROPERTY LINES,
OR IMPROVEMENTS AND THE PASSAGE OF TIME
WILL CAUSE IT TO BE INVALID AND OUT OF DATE.

DATE OF SURVEY: APRIL 6, 2016

[Signature]
B.C. LAND SURVEYOR

THIS DOCUMENT IS NOT VALID UNLESS
ORIGINALLY SIGNED AND SEALED.

BRIDGE STREET

- 1) Encourage cycling as a means of travel by calming automobile traffic within McLennan South and supporting the City Centre policies and programs for bicycles.

Circulation Map *Bylaw 8803
2011/10/17*

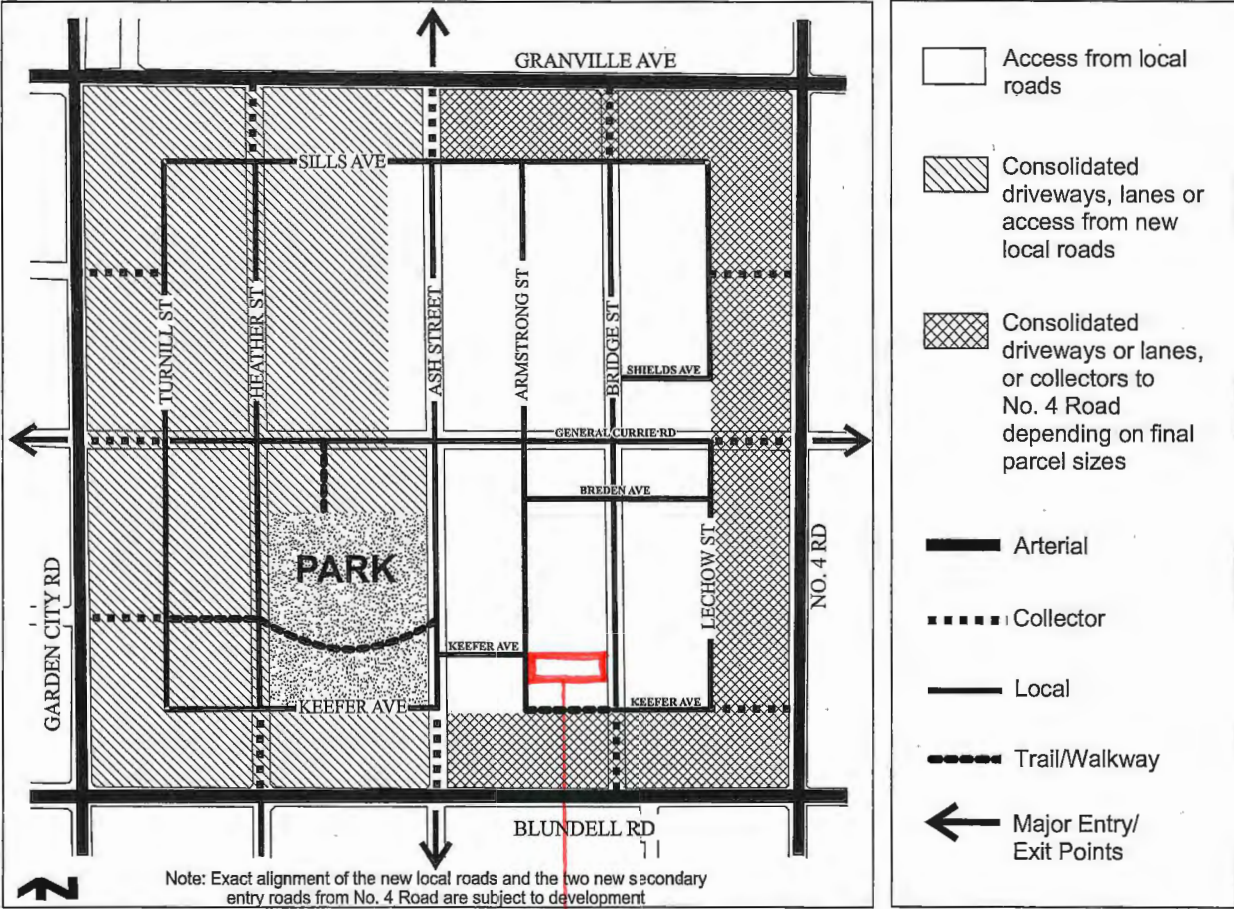

SUBJECT
PROPERTY

City of Richmond

Land Use Map

Bylaw 9106
2015/09/14

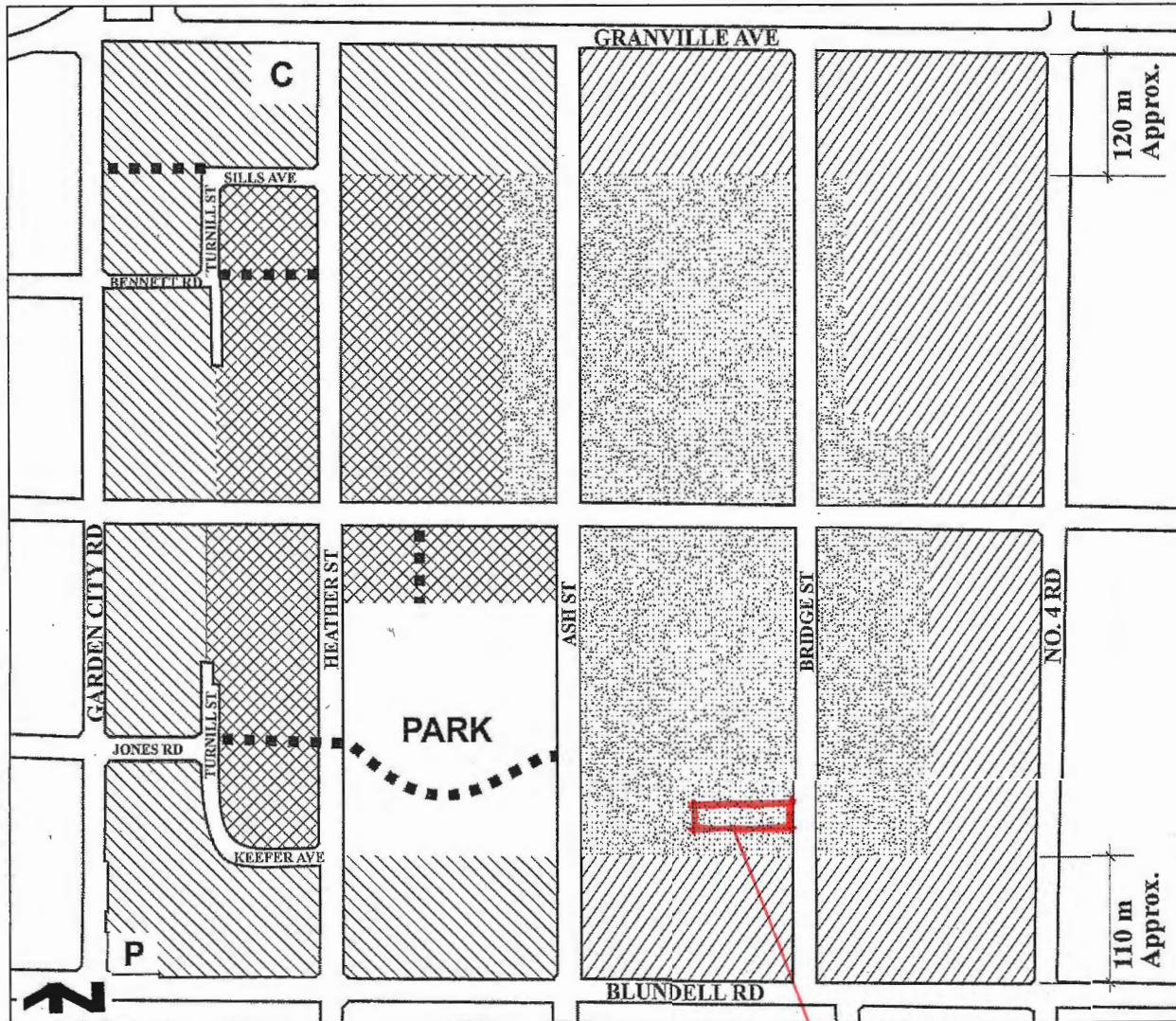

Residential, Townhouse up to 3 storeys over 1 parking level, Triplex, Duplex, Single-Family 0.75 base F.A.R.	Residential, Historic Single-Family, 2 ½ storeys maximum 0.55 base F.A.R. , Lot size along Bridge and Ash Streets: <ul style="list-style-type: none"> • Large-sized lots (e.g. 18 m/59 ft. min. frontage and 550 m²/ 5,920 ft² min. area) Elsewhere: <ul style="list-style-type: none"> • Medium-sized lots (e.g. 11.3 m/ 37 ft. min. frontage and 320 m²/ 3,444 ft² min. area), with access from new roads and General Currie Road; Provided that the corner lot shall be considered to front the shorter of its two boundaries regardless of the orientation of the dwelling.	Trail/Walkway C Church P Neighbourhood Pub
Residential, 2 ½ storeys typical (3 storeys maximum) Townhouse, Triplex, Duplex, Single-Family 0.60 base F.A.R.		
Residential, 2 ½ storeys typical (3 storeys maximum), predominantly Triplex, Duplex, Single-Family 0.55 base F.A.R.		

Note: Sills Avenue, Le Chow Street, Keefe Avenue, and Turnill Street are commonly referred to as the “ring road”.



Froggers Creek Tree Consultants Ltd.

Appendix 1

Tree Protection Fencing Detail

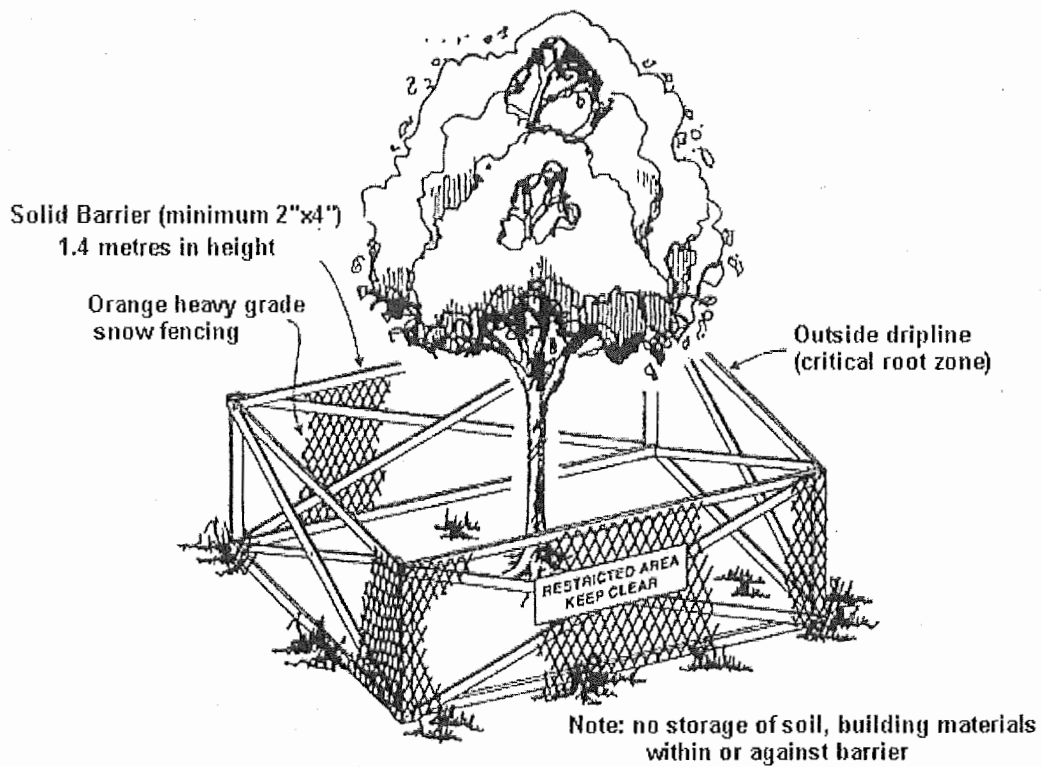

**APPENDIX 2
TREE INVENTORY**

ON-SITE TREES

#	Type	Action	Reason	DBH	MPZ	NFZ	Ht	CR	Health	Structural Condition
1	Cherry	Remove	Has permit	35cm	2.1m	3.4m	3m	1m	Poor	Topped hard
2	Apple	Retain		20cm	1.2m	2.5m	3m	2m	Fair	Leaning
3	Fruiting Plum	Retain		11/10/9cm	1.6m	2.9m	3m	1m	Fair	Pruned hard
4	Lawson Cypress	Retain		42cm	2.5m	3.8m	15m	3m	Fair	Co-dominant trunks

CITY TREES

5	Douglas fir	Retain	City should consider removal	80cm	4.8m	6.1m	20m	6m	Poor	Appears to have been critically impacted by construction 10 years ago. The water line is only a couple feet from the trunk
---	-------------	--------	------------------------------	------	------	------	-----	----	------	--

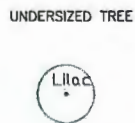
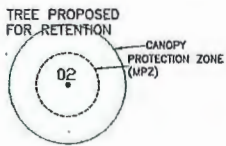
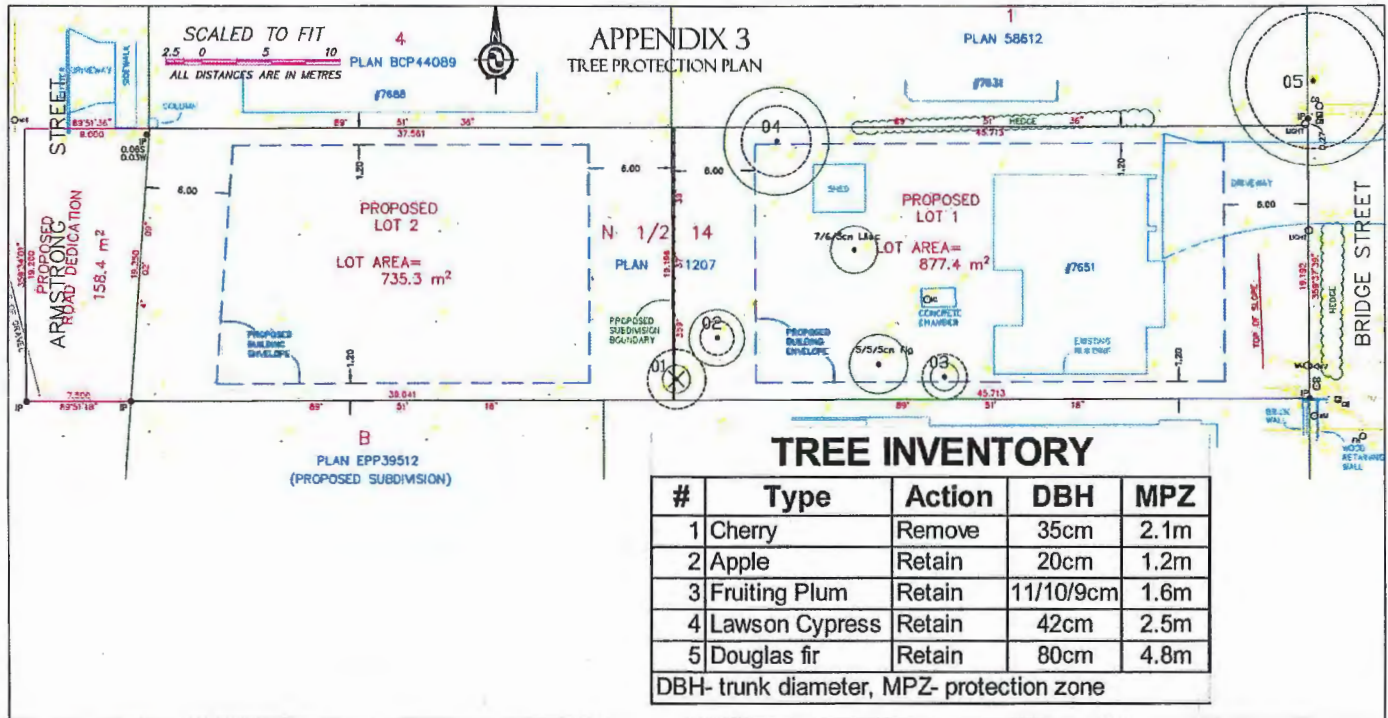

Page 8

- NOTES:
1. SITE LAYOUT INFORMATION AND TREE SURVEY DATA PER SUPPLIED DRAWING
 2. REFER TO ATTACHED TREE PROTECTION REPORT FOR INFORMATION CONCERNING TREE SPECIES, STEM DIAMETER, HEIGHT, CANOPY SPREAD AND CONDITION.
 3. ALL MEASUREMENTS ARE METRIC

Froggers Creek
Tree Consultants Ltd

7743 McDougall Avenue Burnaby BC V5M 4R1
Telephone: 604-731-6002 Fax: 604-457-0970

7451 Bridge Street Richmond BC

TREE PROTECTION PLAN
THE DRAWING PLOTS ALL TREES, PROPOSED FOR RETENTION, REMOVAL, TRIM CANOPES, PROTECTION ZONES AND PROTECTION FENCING IN RELATION TO PROPOSED LAYOUT.

DATE: 01/04/2018



City of Richmond

Rezoning Considerations Fast Track Application Planning and Development Division

Address: 7651 Bridge Street

File No.: RZ 16-721609

Prior to final adoption of Richmond Zoning Bylaw 8500, Amendment Bylaw 9561, the applicant is required to complete the following:

1. A road dedication along the entire Armstrong Street frontage; starting at 9.0 m at the northwest corner, tapering to 7.5 m at the southwest corner (158.4 m²).
2. Submission of a Contract entered into between the applicant and a Certified Arborist for supervision of any on-site works conducted within the tree protection zone of the trees to be retained. The Contract should include the scope of work to be undertaken, including: the proposed number of site monitoring inspections, and a provision for the Arborist to submit a post-construction assessment report to the City for review.
3. Submission of a Tree Survival Security to the City in the amount of \$1,500 for the three (3) trees to be retained. After construction and landscaping on-site is completed, the applicant must request a landscaping inspection to verify tree survival. If the trees have survived, 50% of the security will be released. The remaining 50% of the security will be released one year after the initial landscaping inspection if the trees have survived.
4. Submission of a Landscaping Security to the City in the amount of \$1,500 to ensure three (3) trees are planted and maintained on-site according to the requirements established in section 15.14.9 of the proposed zoning bylaw.
5. Registration of a flood indemnity covenant on Title.
6. Registration of a legal agreement on title ensuring that the principal dwelling and any secondary suite cannot be stratified.
7. Registration of a legal agreement on Title to ensure that no final Building Permit inspection is granted until a secondary suite is constructed on each of the two (2) future lots, to the satisfaction of the City in accordance with the BC Building Code and the City's Zoning Bylaw.

Note: Should the applicant change their mind about the Affordable Housing option selected prior to final adoption of the Rezoning Bylaw, the City will accept a proposal to build a secondary suite on one (1) of the two (2) lots and a voluntary contribution of \$2.00 per buildable square foot of the single-family development to the City's Affordable Housing Reserve Fund in-lieu of registering the legal agreement on Title to secure a secondary suite on the second lot.

Prior to Building Permit* Issuance, the applicant must complete the following requirements:

1. Submission of a Construction Parking and Traffic Management Plan to the Transportation Division. Management Plan shall include location for parking for services, deliveries, workers, and loading, application for any lane closures, and proper construction traffic controls as per Traffic Control Manual for works on Roadways (by Ministry of Transportation) and MMCD Traffic Regulation Section 01570.

2. Obtain a Building Permit (BP) for any construction hoarding. If construction hoarding is required to temporarily occupy a public street, the air space above a public street, or any part thereof, additional City approvals and associated fees may be required as part of the Building Permit. For additional information, contact the Building Approvals Division at 604-276-4285.

At Subdivision* or Building Permit* stage, the applicant must complete the following requirements:

1. Installation of appropriate tree protection fencing around all trees to be retained in accordance with the City's Tree Protection Information Bulletin (TREE-03). Tree protection fencing must remain in place until construction and landscaping on the proposed lots are completed.
2. Enter into a Servicing Agreement* for the design and construction of engineering infrastructure improvements. Works include, but may not be limited to, the following:

Water Works:

- Using the OCP Model, there is 437.0 L/s of water available at a 20 psi residual at the Bridge Street frontage. Based on the proposed development, the site requires a minimum fire flow of 95 L/s.
- The Developer is required to:
 - Submit Fire Underwriter Survey (FUS) or International Organization for Standardization (ISO) fire flow calculations to confirm the development has adequate fire flow for on-site fire protection. Calculations must be signed and sealed by a Professional Engineer and be based on Building Permit Stage Building designs.
- At Developers cost, the City is to:
 - Install a new water service connection complete with meter and meter box off of the 100 mm PVC watermain along Armstrong Street to be built via an existing Service Agreement with the owners of 7671 Bridge Street.
 - Install a meter and meter box to the existing service connection serving the east subdivided lot fronting Bridge Street.

Storm Sewer Works:

- The Developer is required to:
 - Retain the existing storm service connection at the northeast corner of the development site.
 - Cut and cap the existing storm service connection at the southeast corner of the development site.
- At Developers cost, the City is to:
 - Install a new storm service connection complete with inspection chamber, off of the 300 mm PVC sewer along Armstrong Street to be built via an existing service agreement with the owners of 7671 Bridge Street.

Sanitary Sewer Works:

- The Developer is required to:
 - Retain existing sanitary service connection at the southeast corner of the development site.
- At Developers cost, the City is to:
 - Install a new sanitary service connection complete with inspection chamber off of the 200 mm sanitary sewer to be built to service the west subdivided lot.

Frontage Improvements:

- The Developer is required to:
 - Underground hydro, telephone, and cable connections for both lots to be created
 - Complete improvements on Armstrong Street including, but not limited to:
 - Road construction consisting of peat removal, sand/gravel base, and asphalt pavement.
 - Sidewalk construction consisting of a concrete curb and gutter; concrete sidewalk; grass boulevard with street trees incorporating a utility corridor with hydro, telephone, gas, and cable; and “Zed” street lighting, to match improvements at 7688 Armstrong Street.
 - Complete improvements on Bridge Street including, but not limited to:
 - Road widening.
 - Sidewalk construction consisting of a concrete curb and gutter, concrete sidewalk near the property line, grass boulevard with street trees incorporating a utility corridor, and “Zed” street lighting, to match improvements at 7611 Bridge Street.
 - Ensure that frontage improvements for both streets are coordinated with those to be completed via the Service Agreement for work at 7671 Bridge Street (SA 14-660787).
 - Coordinate with BC Hydro, Telus and other private communication service providers:
 - To underground Hydro service lines.
 - When relocating/modifying any of the existing power poles and/or guy wires within the property frontages.
 - To determine if above ground structures are required and coordinate their locations on-site (e.g. Vista, PMT, LPT, Shaw cabinets, Telus Kiosks, etc.).

General Items:

- The Developer is required to:
 - Enter into, if required, additional legal agreements, as determined via the subject development's Servicing Agreement(s) and/or Development Permit(s), and/or Building Permit(s) to the satisfaction of the Director of Engineering, including, but not limited to, site investigation, testing, monitoring, site preparation, de-watering, drilling, underpinning, anchoring, shoring, piling, pre-loading, ground densification or other activities that may result in settlement, displacement, subsidence, damage or nuisance to City and private utility infrastructure.

Note:

- * This requires a separate application.
- Where the Director of Development deems appropriate, the preceding agreements are to be drawn not only as personal covenants of the property owner but also as covenants pursuant to Section 219 of the Land Title Act.

All agreements to be registered in the Land Title Office shall have priority over all such liens, charges and encumbrances as is considered advisable by the Director of Development. All agreements to be registered in the Land Title Office shall, unless the Director of Development determines otherwise, be fully registered in the Land Title Office prior to enactment of the appropriate bylaw.

The preceding agreements shall provide security to the City including indemnities, warranties, equitable/rent charges, letters of credit and withholding permits, as deemed necessary or advisable by the Director of Development. All agreements shall be in a form and content satisfactory to the Director of Development.

- Additional legal agreements, as determined via the subject development's Servicing Agreement(s) and/or Development Permit(s), and/or Building Permit(s) to the satisfaction of the Director of Engineering may be required including, but not limited to, site investigation, testing, monitoring, site preparation, de-watering, drilling, underpinning, anchoring, shoring, piling, pre-loading, ground densification or other activities that may result in settlement, displacement, subsidence, damage or nuisance to City and private utility infrastructure.
- Applicants for all City Permits are required to comply at all times with the conditions of the Provincial *Wildlife Act* and Federal *Migratory Birds Convention Act*, which contain prohibitions on the removal or disturbance of both birds and their nests. Issuance of Municipal permits does not give an individual authority to contravene these legislations. The City of Richmond recommends that where significant trees or vegetation exists on site, the services of a Qualified Environmental Professional (QEP) be secured to perform a survey and ensure that development activities are in compliance with all relevant legislation.

Signed

Date



Richmond Zoning Bylaw 8500
Amendment Bylaw 9561 (RZ 16-721609)
Portion of 7651 Bridge Street

The Council of the City of Richmond, in open meeting assembled, enacts as follows:

- 1. The Zoning Map of the City of Richmond, which accompanies and forms part of Richmond Zoning Bylaw 8500, is amended by repealing the existing zoning designation of the following area and by designating it "SINGLE DETACHED (ZS14) - SOUTH MCLENNAN (CITY CENTRE)".

That area shown cross-hatched on "Schedule A" attached to and forming part of Bylaw No. 9561

- 2. This Bylaw may be cited as "Richmond Zoning Bylaw 8500, Amendment Bylaw 9561".

FIRST READING

A PUBLIC HEARING WAS HELD ON

SECOND READING

THIRD READING

OTHER CONDITIONS SATISFIED

ADOPTED

Series of horizontal lines for recording readings and conditions.

CITY OF RICHMOND APPROVED by [Signature] APPROVED by Director or Solicitor [Signature]

MAYOR

CORPORATE OFFICER