



City of Richmond

Report to Committee

To: Public Works & Transportation Committee

Date: September 12, 2018

From: Jim Young, P.Eng.
Senior Manager,
Capital Buildings Project Development

File: 06-2050-01/2018-Vol 01

Kim Somerville
Manager, Community Social Development

Re: **City Buildings – Enhanced Accessibility Design Guidelines and Technical Specifications**

Staff Recommendation

That the proposed “City of Richmond Enhanced Accessibility Design Guidelines and Technical Specifications” presented as Attachment 1 of this report, and as described in the report dated September 12, 2018, from the Senior Manager, Capital Buildings Project Development and Manager, Community Social Development, be endorsed and used in planning for future corporate facilities.

Jim Young, P. Eng.
Senior Manager,
Capital Buildings Project Development
(604-247-4610)

Kim Somerville
Manager, Community Social Development
(604-247-4671)

Att. 1

REPORT CONCURRENCE		
ROUTED TO:	CONCURRENCE	CONCURRENCE OF GENERAL MANAGER
Building Approvals	<input checked="" type="checkbox"/>	
Development Applications	<input checked="" type="checkbox"/>	
Transportation	<input checked="" type="checkbox"/>	
REVIEWED BY STAFF REPORT / AGENDA REVIEW SUBCOMMITTEE	INITIALS: 	APPROVED BY CAO

Staff Report

Origin

This report proposes to replace the existing “Accessibility Guidelines for City-Owned Buildings” (“1994 Guidelines”), with the proposed updated “City of Richmond Enhanced Accessibility Design Guidelines and Technical Specifications” (“2018 Guidelines”), presented as Attachment 1.

This report supports Council’s 2014-2018 Term Goal #1 A Safe Community:

Maintain emphasis on community safety to ensure Richmond continues to be a safe community.

This report supports Council’s 2014-2018 Term Goal #2 A Vibrant, Active and Connected City:

Continue the development and implementation of an excellent and accessible system of programs, services, and public spaces that reflect Richmond’s demographics, rich heritage, diverse needs, and unique opportunities, and that facilitate active, caring, and connected communities.

This report supports Council’s 2014-2018 Term Goal #3 A Well-Planned Community:

Adhere to effective planning and growth management practices to maintain and enhance the livability, sustainability and desirability of our City and its neighbourhoods, and to ensure the results match the intentions of our policies and bylaws.

The Development of these 2018 Guidelines is in keeping with the Council-adopted *Social Development Strategy (2013-2022)*, specifically the recommended Action 3, which speaks to improving accessibility in the community.

Action 3 – Continue to play a leadership role with respect to physical accessibility, consulting people with disabilities and other partners in efforts to:

3.5 Promote best practices in the assessment and upgrading of accessibility features in City and non-City facilities (e.g. continued participation with the Rick Hansen Foundation and others on the promotion and enhancement of the Planat online venue accessibility rating tool.

3.6 Develop a comprehensive plan with associated budget requirements, for undertaking necessary upgrades to further increase accessibility of existing City facilities.

3.7 Ensure that, to the extent possible, City facilities and the public realm (e.g. parks, sidewalks) are accessible.

These updated 2018 Guidelines seek to improve on the previous guidelines so that it meets current enhanced accessibility design concepts and updated industry standards and practices. A few examples the 2018 Guidelines exceeding the BC Building Code (BCBC) are as follows:

- Contrasting colour and texture for flooring at the centreline of the path of pedestrian travel, particularly at entrances and elevators. The BCBC only requires tactile warning strips at the top of a stairway and at intermediate stairway landings;
- Generally larger clear space and passage for enhanced manoeuvrability of wheelchairs and scooters. For example, BCBC requires a minimum corridor width of 1,100mm whereas the updated Guidelines recommend 1,829mm to allow for passage of two wheelchairs or BCBC's minimum doorway width of 800mm and the Guideline's recommendation of 914mm;
- Elevator cab to incorporate verbal audible messaging identifying floors and available directions of travel. BCBC does not specify this; and
- Incorporating additional visual and audible cues or systems as well as digital and communication technologies (such as hearing loops, use of wayfinding mobile technology, audible, visual and tactile feedback, message boards, etc.) to convey information and assist with wayfinding. BCBC specifies audio and visual signal devices for emergency warning systems only.

The proposed Guidelines will be used in planning for future City building projects and renovation of existing City buildings. The preparation of the guidelines was jointly coordinated by the Community Social Development and Capital Building Project Development departments.

Analysis

Consultation on Guidelines

The proposed "City of Richmond Enhanced Accessibility Design Guidelines and Technical Specifications" were developed to assist the design of enhanced accessibility features exceeding the BC Building Code for all corporate facilities as future civic assets.

During the process of developing the guidelines and technical specification, a number of internal and external stakeholder meetings were held to solicit input on the consultant's initial draft. An internal Steering Committee was created to lead and endorse the process and was comprised of City staff from the following departments:

- Building Approvals;
- Development Applications;
- Facility Services;
- Public Works Administration;
- Real Estate Services; and
- Transportation.

External meetings were held with the following:

- Alzheimer's Society of BC;
- Barrier Free BC;
- Developmental Disabilities Association;

- Richmond Centre for Disability;
- Richmond Seniors Advisory Committee;
- Richmond Society for Community Living; and
- Vancouver Coastal Health.

Policy and Principles

The preparation of the proposed “City of Richmond Enhanced Accessibility Design Guidelines and Technical Specifications” is consistent with Council’s commitment to accessibility and the Social Development Strategy. It fulfills Council’s direction to promote best practices in the assessment and upgrading of accessibility features in City and non-City facilities. The document is intended to guide the accessibility design and development of City built facilities constructed as capital projects and City facilities built by developers as community amenity contributions related to rezoning processes. It is not intended to be used for privately initiated facility projects; however, it may serve as a useful reference for those involved with such projects and for developer amenity contribution discussions.

The following principles developed by the Steering Committee were applied to the development of these guidelines and technical specifications:

- provide for accessibility in all buildings and public spaces, indoors and outdoors;
- provide for principles of equity in new developments;
- commitment to principles of visitability for people of all physical abilities in buildings and public spaces;
- commitment to assisting to care for Richmond citizens who are part of vulnerable groups;
- commitment to partnering with community health, stakeholder and other organizations that assist with generating healing and accessible environments;
- development of resilient and sustainable buildings that incorporate principles of accessibility that are durable and that minimize maintenance costs over the life of the facility;
- commitment to sound public finance economic practice and working pro-actively with all stakeholders in the delivery of accessible buildings and public spaces; and
- commitment to public engagement on the delivery of accessibility in buildings and public spaces to meet the needs of the community.

Benefits

The proposed “City of Richmond Enhanced Accessibility Design Guidelines and Technical Specifications” will help reduce staff time spent guiding developers, designers and consultants about what to consider when building new facilities. The document provides a reference tool that can be used to assist with preparing design elements that enhance accessibility and offers direction about how to incorporate accessibility features.

The intent of these 2018 Guidelines is to promote enhanced accessibility and barrier-free access for all Richmond citizens and foster independence and mobility in all parts of the city.

Implementation

Once approved, the “City of Richmond Enhanced Accessibility Design Guidelines and Technical Specifications” document will be used by City staff to guide accessibility design of all City facilities and be posted on the City’s web site and made available to developers contemplating making a community amenity contribution as part of a rezoning application. For future developer-built or City projects, the document will provide guidance on accessibility parameters required.

Next Steps

Policy No. 2012 City Buildings – Accessibility (adopted on February 14, 1994) to be amended and to reflect the proposed updated accessibility guidelines be presented for Council consideration.

It is expected that the guidelines will need to be revised from time to time based on potential changes to the BC Building Code, sustainable building practices and lessons learned from the various facility projects. Staff will continue to collect this information and engage external stakeholders in further enhancement of the guidelines which will be brought forward to Council in future revisions as required.

Financial Impact

None.

Conclusion

Staff recommend that the proposed updated “City of Richmond Enhanced Accessibility Design Guidelines and Technical Specifications”, be approved and used for future City facilities either constructed by the City as capital projects or by developers as community amenity contributions.

With an ageing population and an increasing need to enhance independence for people with physical, sensory and cognitive challenges, there is a need to exceed minimum standards for accessibility whenever possible.



Martin Younis, B.Eng., M.Eng.
Senior Project Manager
(604-204-8501)



Kim Somerville
Manager, Community Social Development
(604-247-4671)

LH:lh

Att. 1: Enhanced Accessibility Design Guidelines and Technical Specifications (June 2018)



City of
Richmond

Enhanced Accessibility

Design Guidelines and Technical Specifications
June 2018

CNCL - 235



Table of Contents.....	i	18
Executive Summary.....	iii	19
1.0 Introduction.....	1	20
1.1 Mission Statement.....	1	21
1.2 Intent of Guidelines and Specifications and How They Are to be Applied.....	1	21
1.3 City of Richmond's Commitment to Accessibility and Enhanced Accessibility.....	1	22
1.4 The Changing Regulatory Environment Concerning Accessibility in Canada.....	2	23
1.5 Principles of Accessibility and Universal Design.....	3	25
1.6 How the Development Process in the City of Richmond Works, and How Principles to Incorporate Enhanced Accessibility in Buildings and Open Spaces Can be Integrated into the Development Process....	4	26
2.0 A Glossary of Definitions Pertaining to Accessibility in Buildings and Public Spaces.....	5	26
3.0 Understanding Accessibility Requirements.....	11	27
3.1 Meeting Community Needs.....	11	27
3.2 Preferred Dimensions to Enhance Accessibility.....	11	28
3.2.1 Wheelchairs - Clear Space.....	11	31
3.2.2 Wheelchairs - Reach Requirements.....	12	31
3.2.3 Requirements for Power Wheelchairs and Scooter Maneuvering.....	12	32
3.2.4 Requirements for Persons Accompanied by Certified Guide or Service Dogs.....	13	32
3.2.5 Acoustic Considerations for those who are Hard of Hearing....	13	33
4.0 General Design Considerations to Enhance Accessibility.....	15	34
4.1 Corridors and Paths of Travel.....	15	34
4.2 Gates and Turnstiles.....	16	35
4.3 Ramps.....	16	35
4.4 Stairs.....	17	36
4.5 Colour and Texture.....	17	36
4.6 Signage.....	18	36
4.7 Spatial Requirements at Drinking Fountains and Bottle Fillers.....	19	37
4.8 Clearances at Mailboxes and Vending Machines.....	20	37
4.9 Waiting, Queuing and Seating Areas.....	20	37
4.10 Interior Finishing.....	21	37
4.10.1 Flooring.....	21	37
4.10.2 Walls.....	21	37
4.10.3 Ceilings.....	22	37
4.10.4 Doors and Entrances.....	23	37
4.10.5 Windows, Glazed Screens and Sidelights.....	25	37
4.10.6 Reception and Information Counters.....	26	37
4.10.7 Elevators, Lofts and Escalators.....	26	37
4.10.8 Work Stations and Shelving.....	27	37
4.10.9 Staff Kitchens.....	27	37
4.10.10 Washroom Facilities.....	28	37
• Typical Male and Female Washrooms.....		
• Universal Washrooms.....		
• Shower Stalls.....		
4.10.11 Lockers and Storage Areas.....	31	37
4.10.12 Controls and Operating Mechanisms.....	31	37
4.10.13 Emergency Exits and Areas of Refuge.....	32	37
4.10.14 Security Considerations and Alarms.....	32	37
4.10.15 Indoor Lighting Considerations.....	32	37
4.11 Streetscape Considerations.....	33	37
4.12 Parking Area Considerations.....	34	37
4.13 Passenger Loading Zone Considerations.....	35	37
4.14 Outdoor Recreational Facilities.....	35	37
4.15 Drop-off and Pick-up Shelters.....	36	37
4.16 Outdoor Lighting Considerations.....	36	37
5.0 Technical Specifications.....	37	37
6.0 Checklists For Enhanced Accessibility.....	43	43

These City of Richmond Enhanced Accessibility Design Guidelines and Technical Specifications [“The Guidelines”] were approved by City Council on (mm/dd/yyyy) as an administrative document to be updated from time to time.

The City of Richmond provides these Guidelines to assist City staff and the development community in the incorporation of accessibility features in City-owned or City leased premises, that go beyond the requirements of the BC Building Code for accessibility in public buildings. The Guidelines are provided as well to the public as a resource on an information only basis.

Therefore, while the content is thought to be accurate on the publication date shown, the Guidelines are provided on an “as is” basis, and without warranty of any kind, either expressed or implied.

The City of Richmond, its elected officials, officers, agents, employees and contractors will, in no event, be liable or responsible for losses or damages of any kind arising out of the use of the Guidelines. Additionally, changes may be made to the Guidelines without prior notice.

The information contained in the Guidelines is subject always to the provisions of all governing legislation and bylaws including, without limitation, the BC Building Code, the City of Richmond Zoning Bylaw 8500, the City of Richmond Building Regulation Bylaw 7230, and the City of Richmond Subdivision and Development Bylaw 8751, including all as they may be amended or replaced from time to time.

The City of Richmond is committed to incorporating principles of accessible design in all buildings and open spaces in the City. This is especially true for City-owned facilities, and ongoing efforts are made to ensure that the design and construction of Richmond's public infrastructure reflects a strong commitment to accessible design requirements.

An essential aspect of this commitment to accessibility is the need to keep abreast with requirements for accessibility and inclusivity as they occur over time in Richmond. City Policies have in the past, articulated such objectives. City Policy 4012 – Access and Inclusion, emphasizes this, and commits to:

- developing programs and adopting practices to ensure Richmond residents and visitors have access to a range of opportunities to participate in the economic, social, cultural and recreational life of the City;
- collaborating with senior levels of government, partner organizations and stakeholder groups to promote social and physical infrastructure to meet the diverse needs of people who visit, work and live in Richmond; and
- promoting barrier free access to the City's facilities, parks, programs and services.

The City of Richmond Building Bylaws and the Provincial Building Code typically provide for the minimum requirements for accessibility in buildings and public spaces. These regulations are informed by the BC Office of Housing and Construction Standards "BC Access Handbook (2014)", which provides an illustrated commentary, describing and suggesting how many of the Code requirements can be implemented.

Across Canada, there is a growing trend for more and more provinces and municipalities to go beyond minimum standards, and to establish new guidelines and regulations that enhance accessibility, particularly in public buildings and open spaces. Generally, this shift in attitude is in response to the changing needs of an aging society, which has greater numbers of people who are experiencing changes to their abilities, and who require more design supports in the built environment to assist them to live as healthy and independent lives as possible.

The intent of these Design Guidelines and Technical Specifications for Enhanced Accessibility - to keep pace with new attitudes and commitments to people's health and independence - and to provide guidelines for City-owned buildings and public spaces that go beyond basic codes for accessibility.

In addition to input from City staff, the preparation of these Design Guidelines has relied on consultation with key stakeholders and advocates for those living with diverse abilities. The contributions of these groups are recognized with thanks in the Acknowledgements section of the document. This document has also been informed by a survey of work in the field and best practices from other jurisdictions in Canada.

It is hoped that by enhancing accessibility in City-owned buildings and public spaces, Richmond can play a leadership role, and can promote better standards for accessible design in privately developed buildings throughout the City.



1.1 Mission Statement

The City of Richmond is committed to incorporating principles of accessible design in all buildings and open spaces in the City. The City is also committed to moving beyond the basic building code requirements for accessibility, and wishes to promote “enhanced accessibility” and barrier-free access for all Richmond citizens. The goal is to help foster independence and mobility in all parts of the City for every person, no matter what their degree of physical or cognitive ability might be.

1.2 Intent of Guidelines and Technical Specifications and How They Are to be Applied

In the City of Richmond, accessibility and “enhanced accessibility” in buildings and streets/sidewalks and open spaces, is typically mandated through the city’s development approvals and building permitting processes.

The Richmond Building Bylaws and the Provincial Building Code provide minimum requirements for accessibility for persons with diverse abilities, including individuals who have had a loss or reduction of functional ability, people living with a sensory or cognitive disability, impairments, or those living with a form of dementia.

The intent of these Guidelines and Technical Specifications is to provide information for the public, and to provide clarity for building owners, developers, architects, and others in the development industry, regarding the City’s expectations for going beyond minimum requirements, and providing for enhanced design and delivery of accessibility in buildings and in the public realm.

More specifically, these Guidelines and Technical Specifications are intended to define expectations and guide the City’s decisions for the design of all City-owned buildings, whether for a new build or a renovation of an existing City facility.

1.3 City of Richmond’s Commitment to Accessibility and Enhanced Accessibility

The City has a strong history of facilitating accessibility in buildings and public spaces. Richmond’s “Social Development Strategy” (2013), sets out that the City is an inclusive, engaged and caring community, and one that commits to enhancing accessibility and addressing the needs of an aging population.

More specifically, under Social Development Strategy Strategic Direction #2, the City supports:

- *promoting best practices in the assessment and upgrading of accessibility features in City and non-City facilities.*
- *developing a long term plan to undertake the necessary upgrades to further increase the accessibility of existing City facilities.*
- *ensuring that City facilities and the public realm are as accessible as possible.*

Richmond’s City Council Policies 2012 and 4012 reiterate goals set out in the Social Development Strategy, namely to:

- *acknowledge and keep abreast of the accessibility and inclusive needs and challenges of diverse population groups in Richmond.*
- *collaborate with senior levels of government, partner organizations and stakeholder groups to promote the development of physical infrastructure to meet the diverse needs of people who work, visit and live in Richmond.*



Park path.

- The City of Richmond continues to support goals for accessibility and enhanced accessibility, based on the following core planning principles:
- provide for accessibility in all buildings and public spaces, indoors and outdoors.
 - commitment to principles of equity in new developments.
 - commitment to principles of visitability for people of all physical abilities in buildings and public spaces.
 - commitment to assisting to care for Richmond citizens who are part of vulnerable groups.
 - commitment to partnering with community health, stakeholder and other organizations that assist with generating healing and accessible environments.
 - development of resilient and sustainable buildings that incorporate principles of accessibility, that are durable and that minimize maintenance costs over the life of the facility.
 - commitment to sound public finance economic practice, and working pro-actively with all stakeholders in the delivery of accessible buildings and public spaces.
 - commitment to public engagement on the delivery of accessibility in buildings and public spaces, to meet the needs of the community.



Accessible Route Highlighted by Paving Contrast.

1.4 The Changing Regulatory Environment Concerning Accessibility in Canada
Typically, new builds or renovated private buildings in Canada must comply with the minimum requirements for accessibility that are set out in the Building Codes adopted by the various Provinces.

In British Columbia, the 2012 BC Building Code sets out the minimum requirements for accessibility in buildings and public spaces, and these regulations are further informed by the Building Access Handbook 2014, published by the BC Office of Housing and Construction Standards. The Handbook provides an illustrated commentary, suggesting how many of the code requirements may be implemented.

However, for publicly owned and funded buildings, a growing number of provinces and municipalities are opting to go beyond minimum standards and are establishing new sets of regulations to enhance accessibility in buildings.

The work of this document to enhance accessibility emulates what many other municipalities and provincial jurisdictions are already doing, and also anticipates new federal legislation that is presently being formulated that will enforce a higher degree of accessibility-related regulations for the construction of buildings and public spaces in the future.

Until Canada passes legislation similar to the United States' "Americans with Disabilities Act [2010]", the most nationally recognized and recommended accessible design guide is CAN/CSA B651, Accessible Design for the Built Environment". This document refers to and summarizes some of the standards described in CAN/CSA B651, but also includes references to best practices adopted already in other jurisdictions in Canada.

One such best practices guide is: Ontario's Accessibility for Ontarians with Disabilities Act [AODA]
In 2005, Ontario passed the Accessibility for Ontarians with Disabilities Act, with the goal of making buildings and public spaces accessible by 2025. The Act created standards for businesses and government and non-government organizations to follow --- to identify and remove barriers that prevent people with disabilities having opportunities to participate in every day life.

The Integrated Accessibility Standards Regulation now requires that all businesses and organizations provide a Declaration of Compliance with the provisions of the Act, with first reporting due by 31 December 2017.

1.5 Principles of Accessibility and Universal Design

Richmond residents and visitors have varying degrees of physical ability and levels of comfort in participating in the activities of everyday life. "Enhanced Accessibility" in buildings, also referred to as "barrier-free design" or "universal design", allows for easier and safer use of buildings and public spaces for the public in general. Such design guidelines promote ease of user access and safety that benefit all citizens, from parents pushing strollers to tradespeople dealing with the loading and unloading of goods.

In all, "Universal Design" aspires to benefit each member of the population by promoting accessible and usable products, services and built environments.

The Seven Principles of Universal Design were developed in 1997 by a working group of architects, product designers, engineers and environmental design researchers under the leadership of Ronald Mace of North Carolina State University.

The Seven Principles of Universal Design

[copyright c 1997 NC State University, The Centre for Universal Design]

3 SIMPLE AND INTUITIVE USE
Use of the design is easy to understand, regardless of the user's experience, knowledge, language skills, or current concentration level.



4 PERCEPTIBLE INFORMATION
The design communicates necessary information effectively to the user, regardless of ambient conditions or the user's sensory abilities.



5 TOLERANCE FOR ERROR
The design minimizes hazards and the adverse consequences of accidental or unintended actions.

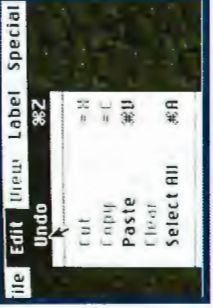

6 LOW PHYSICAL EFFORT
The design can be used efficiently and comfortably and with a minimum of fatigue.

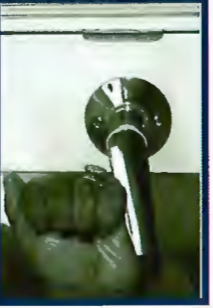

1 EQUITABLE USE
The design is useful and marketable to people with diverse abilities.



2 FLEXIBILITY IN USE
The design accommodates a wide range of individual preferences and abilities.



7 SIZE AND SPACE FOR APPROACH AND USE
Appropriate size and space is provided for approach, reach, manipulation, and use regardless of user's body size, posture, or mobility.



1.6 How the Development Process in the City of Richmond Works, and How Principles to Incorporate Enhanced Accessibility in Buildings and Open Spaces Can be Integrated into the Development Process

- Overview of the Process

The City collaborates with the public, the development community, various stakeholders in the non-profit sector, and other involved groups, to create high quality, fully accessible buildings and open spaces.

To facilitate this process, it is important for building and public space project proposal applicants to follow an appropriate development methodology in order to promote applications that successfully promote principles of enhanced accessibility and universal design. An overview of the process would include:

- review City and Provincial guidelines and requirements for accessibility and enhanced accessibility for new City-owned projects and renovations.
- review of the typical approvals process, including preliminary project discussions with City staff.
 - City Approvals
 - Modified Development Permit Process for City-Owned Buildings
 - a development application for the project, comprised of design drawings that incorporate City and Provincial requirements for Accessibility, as well as expectations for Enhanced Accessibility including these Design Guidelines and Technical Specifications, and any other related guidelines or regulations.
 - Building Permit
 - City approval that allows construction to begin, comprised of working drawings and specifications that demonstrate compliance with the Building Code and Development Permit requirements.
 - Occupancy Permit
 - City final approval of the constructed facility, indicating that it is ready for use.



The City of Richmond wants to enhance the accessibility of its City-owned buildings, for the public and City staff and officials.

2.0 A Glossary of Definitions Pertaining to Accessibility in Buildings and Public Spaces

Developments incorporating accessibility and enhanced accessibility have a descriptive and regulatory language that is specific to the needs and requirements of this “barrier-free” and “universal design” philosophy.

Access Aisle

A pedestrian space that provides satisfactory clearances between specific elements, such as parked cars or desks or seating, and which provides for accessible use.

Accessibility

A design standard that allows for persons with diverse abilities to approach, enter, pass to and from, and make use of an area and its facilities, without the assistance of a third party or caregiver. Accessibility allows for independence of use and movement by individuals who live with diverse abilities.

Accessible Route

A continuous and clear path of travel that is unobstructed by vertical or over-hanging elements, as well as any encroaching or protruding horizontal elements.

Interior accessible routes may include hallways, ramps, or specific floor areas such as clear spaces at doors or furnishings or fixtures.

Exterior access routes may include sidewalks and crossings, curb cuts and ramps, parking access aisles and building exits and entrances.

Active Transportation Routes

Refers to human-powered transportation modes such as walking, cycling or rolling. Providing for barrier-free design typically enhances the functionality of Active Transportation Routes, as well as enhancing their accessibility for people with diverse abilities or those using mobility devices such as walkers, wheelchairs and scooters, and people using certified guide dogs.



Active Transportation Routes.

Adaptable Buildings and Public Spaces

Refers to anticipating future needs, or changing aspects of existing buildings and public spaces to make them more functionally useful to people with different degrees of disability. For example, bathrooms can be constructed with backing in the wall construction, to enable the addition of grab bars in the future, to enhance accessibility in years to come.

Aging in Place

The ability to live in one’s home for as long as possible. This will often depend on the living space being adaptable in order to assist with health and wellness goals.

Area of Refuge [Area of Rescue Assistance]

A floor area with direct access to a building exit, where individuals who cannot use stairs can wait in relative safety, until assisted or instructed to evacuate the building. An area of rescue assistance can also be located at an exterior location, where individuals can wait for help to arrive.

Assistive Listening Device

Wireless sound transmission systems that improve sound reception for persons with hearing impairments. Such systems provide adjustable amplification for the user, while blocking out background noise disturbances.

At-Risk Populations

Individuals or households with income or health challenges, and typically whose shelter needs are a concern. Often the health challenges faced include living with diverse abilities.

Automatic Door / Power-Assisted Door

A door equipped with power-operation and controls that open and close the door without manually touching the door. These doors can be swing or automatic sliding door type. Switches for such doors typically are push plates to enable accessibility, and may also include photoelectrical devices, or floor mat actuators.

Barrier

A condition that impedes freedom of movement, or an obstacle or social circumstance that prevents an objective being reached, including access to information.

Barrier-Free Design

A design philosophy that looks to eliminate physical barriers on the ground plane that impede freedom of movement. Primarily concerned with avoiding curbs, steps or changes in grade that make movement in a wheelchair difficult or impossible. Barrier-free design also helps the average person's ease of mobility, since trip hazards are avoided or eliminated.

BC Building Code

The legislation that governs the design and construction of new buildings, additions to buildings, alterations to existing buildings, and the occupancy of any building. The BC Building Code sets out the minimum requirements for accommodating accessibility in buildings.

Cane Detectable

The condition of an object being within the detection range of a user's cane as it sweeps or taps. Typically, cane detectability refers to a mobility cane used by a person who is blind, deafblind, or partially sighted.

Circulation Path

Refers to a way of passage for pedestrians, including walkways, hallways, courtyards, stairways and stair landings. Accessible circulation paths must meet minimum regulatory standards in order to comply with building code requirements.



Barrier-free design incorporates a clear accessible path with cane detectability and good colour contrast.

Clear Space

The minimum unobstructed floor area or ground space required to accommodate a single stationary wheelchair, power wheelchair, scooter, or other mobility device, including the user of the device.

Closed-Circuit Telephone [Enterphone]

Refers to a house or courtesy phone, or a telephone to gain entrance to a building. An appropriate mounting height is installed for the telephone to provide for accessibility.

Colour Contrast and Conspicuity

Research shows that elements are more conspicuous when there is a colour contrast of at least 70%, and with light-coloured characters on a dark background providing the best readability. Colour contrast should be provided on building elements such as stair nosings or signage, to promote legibility for persons who are partially sighted.

Complete Community

A neighbourhood where individuals and households of all income strata, and levels of ability, can be housed with the appropriate design and community supports in order to meet their daily living needs.

Crime Prevention through Environmental Design [CPTED]

An approach to building and urban design which can foster feelings of security for residents and users. CPTED principles should also endeavor to accommodate principles of Enhanced Accessibility.

Diverse Ability

A limitation occurring when an individual's physical environment fails to accommodate his or her functional needs. The experience of a diverse ability can be alleviated by designing environments that accommodate a wide range of physical and sensory abilities.

Egress, Means of

A continuous and unobstructed path of exit travel, in a vertical or horizontal travel direction, or a combination thereof, that provides for an ability to safely leave a building. On upper floors of a building, an accessible means of egress means that exiting is accommodated without the use of stairs, elevators or escalators. In such cases, areas of rescue assistance, such as areas of refuge or protected lobbies, provide a safe refuge until help arrives.

It is also advisable to include an area of refuge outside of the building on the ground level, where people with mobility or cognitive challenges can gather to wait for help to arrive.

Enhanced Accessibility

A barrier-free design philosophy that seeks to go beyond the requirements of the Building Code for accessibility, to foster independence and mobility for all citizens regardless of what their level of individual disability might be.

Entrance

An access point into a building or part of the public realm. The accessibility and spatial requirements of entrances are many, and include an approach walkway, any vertical climb or descent to the entry, the entrance element itself, whether a vestibule is provided at the entry or gate, and what the nature of the entry hardware is at the door or gate. Well-designed entrances are key to providing for enhanced accessibility.

Floor Area Ratio [FAR] or Floor Space Ratio [FSR]

A calculation where the total floor area of a building or development is divided by the area of the site.

Since providing enhanced accessibility is often about providing more space in a building that can often encroach into the maximum FAR or FSR permitted, a municipality may provide floor space exclusions so that economics of development of a building with a level of enhanced accessibility is not the negatively impacted.

Guard

A protective barrier or safety railing used to prevent falling off of a raised platform or floor, or at the open sides of stairs, landings, or raised walkways. The barrier or railing may or may not have openings on it.

Handrail

A building element that provides support for pedestrians, primarily at steps, ramps and stairways, and also at hallways or horizontal passageways, such as corridors in seniors' facilities.

Handrails should be designed for ease of gripping, and provide sufficient clearances to walls or adjacent surfaces.

Healing Environments

Environments that provide appropriate supports to enable users to better deal with physical, intellectual and health-related challenges.

Impairment

Refers to a diminishment of physical or psychological performance or function. The affects of impairment can be alleviated with appropriate building design and attention to detail.

Mixed-Use Development

A building or development that blends two or more uses, including retail, office, institutional and residential uses. Mixed-use developments are more urban in character and should incorporate barrier-free design elements throughout to foster the establishment of complete and accessible communities.

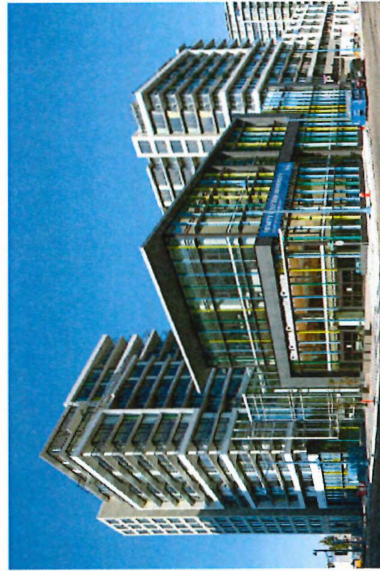

Mixed Use Development.

Multi-Use Pathway

Refers to paths that typically accommodate both bicycle and pedestrian use on the same path system. Both users benefit from a continuous barrier-free design without curbs or steps. Care should be undertaken to design the multi-use path in order to avoid conflicts between pedestrians, and those who use mobility devices such as wheelchairs, strollers, cyclists, scooters, skates and other personal low-powered travel modes.

Operable Portion of Piece of Equipment

The part of a piece of equipment that is used to activate, de-activate or adjust how the equipment performs. These include door handles, push buttons, water fountains, washroom fixtures and accessories, and mail and coin slots, among other items.

Ramp, including Ramp Slope and Cross Slope

A walking surface where the slope is greater than 1:20 [5%]. The maximum ramp slope allowed by code for assembly occupancy or exterior use is 1:10. If possible, the maximum slope should be kept to 1:12. Appropriate landings should be provided in compliance with code requirements.

Cross slopes at ramps should be minimized to allow for surface drainage [maximum 6mm (1/4") in one foot], while not compromising the safety of the ramp.

Handrails and guards are required by code to accommodate safe use of ramps. Regulations for curb cuts or lay-downs to the street level at exterior sidewalks differ from those for ramps.

The dual wheelchair curb cut design is a preferred best practice for crosswalks at intersections, where the centreline of the curb cut ramp lines up with the centreline of the crosswalk.

Includes ramps at the end of pedestrian access aisles for van accessible parking and as defined in City of Richmond Zoning Bylaw 8500 Section 7 Parking and Loading

Resilient Cities and Neighbourhoods

An urban planning strategy that encourages new development to be built for the long term, with an emphasis on a high level of energy utilization, and a reduction in the need to replace buildings systems or components.

Elements that provide accessibility in buildings should be designed with the same level of resilience in mind.

Service Entrance

Typically a non-public entrance, provided for the delivery of goods and services. As such entrances often also provide entry for staff, principles of accessibility should also be considered.



Accessibility should be considered for all drop-off and service entrances.

Sustainability

Meeting present needs without compromising the ability of future generations to meet their needs. Sustainability is described as having four main components: economic, cultural, social and environmental. Providing for accessibility and barrier-free design enhances the social sustainability of urban places for the long term.

Tactile Walking Surface Indicators [TWSI]

A surface treatment on pedestrian walkways, ramps and stairs, that provides a warning for persons who are blind, deafblind, or partially sighted regarding obstructions on the circulation path. As well as providing for colour contrasts, indicator surfaces should be textured differently in order to be cane-detectable.

Technically Not Feasible [Building Renovations and Alterations]

When an existing building is being altered, at times a building upgrade cannot be contemplated because of structural or building services considerations.

In some instances building upgrades that promote use of the building by persons with diverse abilities should be contemplated, even though they do not provide complete compliance with minimum code requirements for new construction, and are "technically not feasible".

An example of such a condition would be the installation of a wheelchair lift in a building that cannot accommodate installation of a code-compliant elevator. [Note: an inadequate budget is not a reason to relax full code compliance].

Transit-Oriented Development [TOD]

An urban planning strategy that looks at encouraging pedestrian-oriented developments by clustering higher density urban developments around public transit infrastructure investments, such as rapid transit stations.

Transit-oriented developments should incorporate accessible design and further benefit from barrier-free and enhanced accessibility strategies.

Signage

Providing for general information or way-finding in buildings and in the public realm, signage should provide for a wide range of effectiveness in communication, and include an appropriate combination of written word, pictorial, and tactile information, including Braille.

Speaking Port

A piece of security equipment that provides for effective two-way communication. Often amplification of voice levels is required to deliver effective communication at speaking ports.

Truncated Domes

Small domes with flattened tops that are inset into paving as tactile warnings at hazardous places such as transit platforms or at stair and ramp landings. They also can act as directional cues for pedestrians at curb edges at curb ramps. (see Figure below).

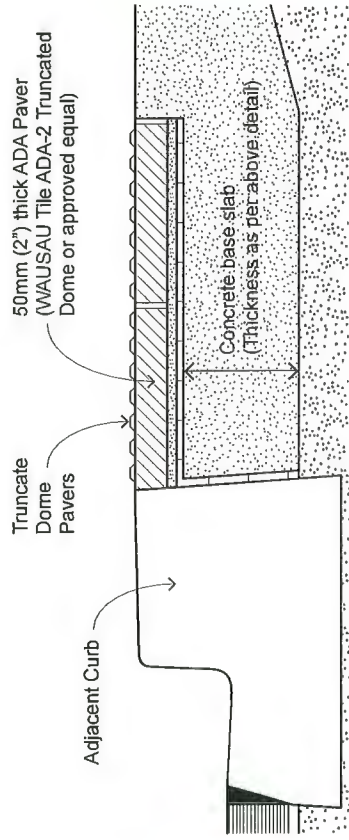

Typical Detail for Truncated Paver Installation. See- Pavers and Tactile Warning Strips Drawing Number: R-18-SD; City of Richmond Engineering Department Supplementary Specifications and Detail Drawings.

Universal Design

The design of spaces, environments and products to be usable by all people, including those with diverse abilities, without the need of specialized design. Universal Design is linked to "Enhanced Accessibility" and barrier-free design, as well as the concept of Visibility.

Visibility

A strategy to change home construction practices, so that all new housing incorporates features that improve access and functional comfort for people with mobility challenges, both in their own homes and in other dwelling units that they may visit.

Wayfinding

The spatial problem-solving process that a person uses to reach a destination. Wayfinding is assisted by orientation clues that can be made available in the local setting, and includes signage, surface textures, colours, illumination, acoustic treatments, and other architectural features. It is especially important to consider wayfinding elements that would assist fostering the independence of people living with diverse abilities.



A sense of place to enhance wayfinding can be created through effective use of colour.

3.0 Understanding Accessibility Requirements

3.1 Meeting Community Needs

Accessibility requirements as set out in the BC Building Code, tend to be conservative, and typically assume for wheelchair users as well as for other persons with physical, sensory or cognitive challenges, that a relatively physically strong individual's needs are being met.

Such an approach tends to overlook the many individuals who not as strong or mobile, or who use a larger mobility device like a power wheelchair or scooter.

These guidelines strives to be more inclusive than the approach set out by code compliance alone, and tries to reflect spatial requirements and design improvements that reflect and serve a wider range of user abilities; hence the goal of delivering "Enhanced Accessibility" for Richmond.

3.2 Preferred Dimensions to Enhance Accessibility

3.2.1 Wheelchairs - Clear Space

The preferred clear space for a wheelchair to make a 360-degree turn is 1829 mm [6'0"]. The preferred clear floor or ground space to accommodate a stationary wheelchair is 762 mm [2'6"] wide x 1219 mm [4'0"] long.

This clear space may be part of the knee or toe space required under all objects, such as counters or sinks. It is important to provide clear accessible space along at least one side of a wheelchair.

Wheelchair 180-degree turning space is accommodated in a corridor at least 1119 mm [3'8"] wide, with a T-shaped contiguous corridor at least 914 mm [3'0"] deep. However, note that it is preferred that public corridors that are meant to be accessible should be 1829 mm [6'0"] wide, and at minimum 1524 mm [5'0"] wide.

Clear space allowances to enhance wheelchair maneuvering also accommodates space requirements for parents with strollers and people using walkers.

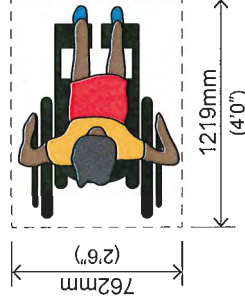

Clear space for Wheelchair.

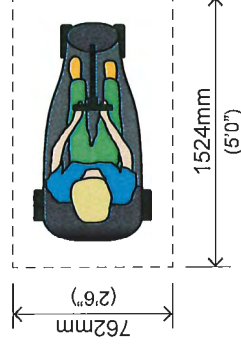

Clear space for Scooter or Power Wheelchair.

Understanding the spatial requirements for people who use mobility devices leads to the creation of more responsive design solutions.

3.2.2 Wheelchairs - Reach Requirements

If the available wheelchair clear space allows a parallel approach to an object, the maximum high side reach should be 1372 mm [4'6"], and the low side reach no less than 330 mm [1'1"] above the finished floor. All switches or other wall-mounted devices should be mounted between 864 mm [2'10"] to 1219 mm [4'0"] maximum above the floor.

Wheelchair reach limits, and those over obstructions and at desks and counters, are summarized in the accompanying diagrams.

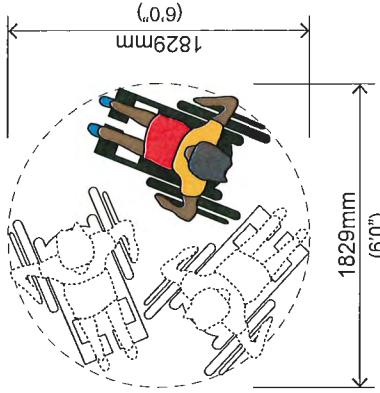

Wheelchair 360° Turning Space (acceptable except where larger space is specified i.e. Individual Washroom).

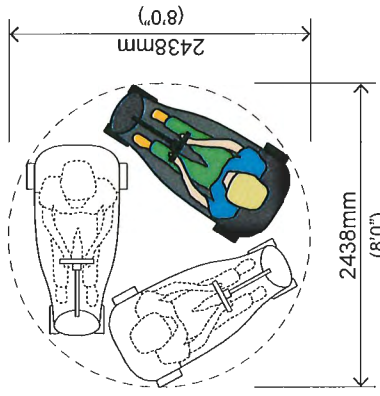

Scooter 360° Turning Space (Preferred).

3.2.3 Requirements for Power Wheelchair and Scooter Maneuvering

- stationary clear space for both a power wheelchair or a scooter is 762 mm [2'6"] wide x 1524 mm [5'0"] long.
- a power wheelchair requires a clear space of 2260 mm x 2260 mm [7'5" x 7'5"] to make a 360-degree turn.
- for a scooter to make a 360-degree turn a clear space of 2438 mm x 2438 mm [8'0" x 8'0"] is required.

The highest forward reach is 1092 mm (3'7") from the floor which allows for a 500 mm (1'8") grasp-reach

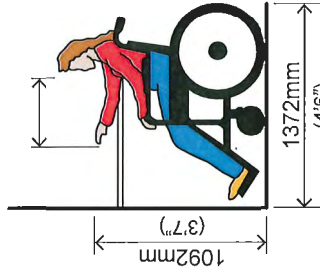

Forward Reach over an Obstruction.

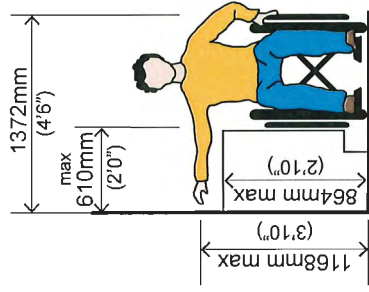

Wheelchair Reach allowance over an Obstruction.

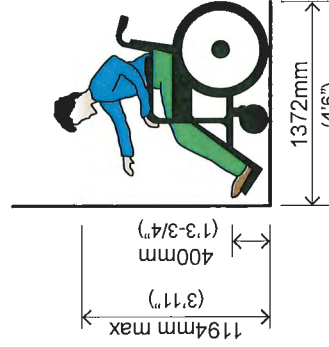

Wheelchair Forward Reach Allowances.

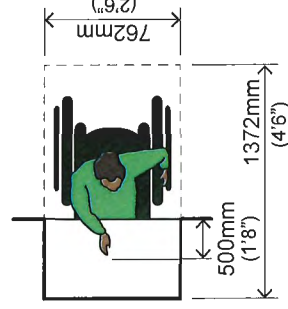

Forward Reach over an Obstruction.

3.2.4 Requirements for Persons Accompanied by Certified Guide or Service Dogs

A minimum width of 1119 mm [3'8"] is required for the clear width of a path of travel. Also note that the cane detectable range for users who are blind, deafblind or partially sighted is between 914 mm [3'0"] and 1524 mm [5'0"].

For protruding objects on walls, or obstructions on the ground plane, it is important that the clear width of travel path not be decreased. If objects project more than 101 mm [0'4"] into the path of travel, a detectable warning surface should be installed flush with the walkway on the ground plane.

When there is a drop-off at the side of the path of travel, a minimum 76 mm [0'3"] high curb should be installed to provide cane detectability. Where the drop off is greater than 254 mm [0'10"], a guard should be installed above the edge protection. Overhead clearance of 2438 mm [8'0"] should be provided for all overhanging obstacles that encroach on the clear path of travel.

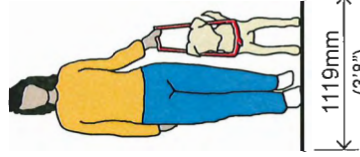

Clear Width for Persons with Service Dog.

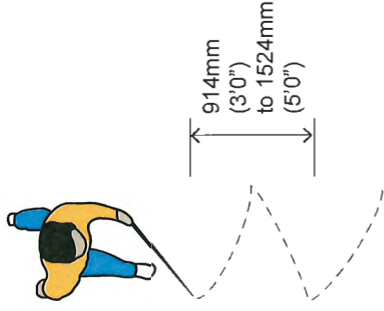

Cane Detectable Range.

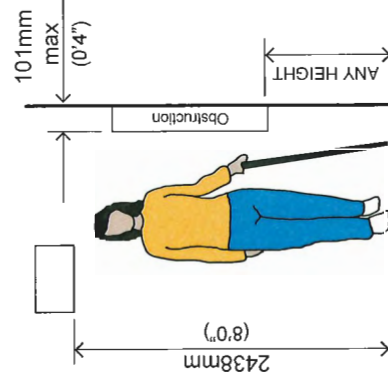

Limits of Protruding Objects.

3.2.5 Acoustic Considerations for those who are Hard of Hearing

Opportunities exist in the design of public buildings, to create acoustic environments that can be extremely useful for people living with diverse abilities. The transmission of sound in different areas of a building can be used as cues for orientation, and can help users navigate within a space. Additionally, appropriate systems to mechanically amplify sound can be installed, to assist in cognitive comprehension in various interior spaces.

Design opportunities include:

- control of sound reflection and sound transmission effects through the choice of sound-reflective or sound absorptive finish materials. Generally, designers should consider how ambient sound can be used to allow people to orient themselves in public lobbies and corridors in buildings, and how disruptive echoing might be dampened in assembly areas.
- avoid creation of unnecessary background noise. Mechanical equipment such as fans and air diffusers should typically be dampened, and ambient effects such as people's voices or exterior traffic noise should be curtailed as much as possible.
- for public address systems, best results occur when the system is zoned to key areas of a building, rather than being a general address system throughout the building. General comprehension is increased when background noise is minimized. For hard-of-hearing users, public address systems should be tied into a visual alert system. A reader board is recommended for better comprehension, so that the public address message is graphically broadcast the same way it is announced.

4.0 General Design Considerations to Enhance Accessibility

4.1 Corridors and Paths of Travel

Routes through buildings and open spaces should accommodate the mobility abilities for a wide range of individuals. The following design principles are to be considered:

- provide the necessary clear width for paths of travel.
- allow for corridor spaces that permit people using wheelchairs or scooters to make 180-degree turns.
- avoid long minimum-width corridors.
- gradual sloped walkways are preferred to ramps or wheelchair lifts in exterior locations.
- avoid changes in flooring or pavement type along a path of travel. Use changes of flooring or ground plane material as delineators of the path of travel, or to signify the presence of an obstruction. Strong colour contrast between path surfaces and delineator surfaces is preferred.
- provide edge protection at changes in level.
- a person using a mobility device such as wheelchair, should not have to exit the building to gain access to another floor.
- it is not appropriate to have only some areas accessible in a building. An accessible route should be provided to link all occupiable building spaces and to allow building staff with mobility challenges the same access in buildings as the public.
- it is preferred that the width of corridor be 1829 mm [6'0"], to allow for two wheelchairs to easily pass each other. At minimum, an accessible corridor should be 1524 mm [5'0"] wide.
- where the longitudinal grade of an accessible path is greater than 1:20 [5%], it should be designed as a code-compliant ramp, with level landings spaced as required for longer ramps and changes in grade.
- wall surfaces in corridors should be non-abrasive.
- where the edges of an accessible route are located beside a vehicular street, or where there is a change of elevation greater than 76 mm [0'3"] between the path and adjacent grade, the edge of the accessible path should be separated with a truncated dome surface, or a 76 mm [0'3"] high curb with colour contrast. Handrails and guards should also be considered, and installed as required by code.
- install wayfinding signage with tactile features where appropriate in public buildings and open spaces, to promote more universal independence of movement.



Straight Run for Wheelchair Ramp is preferred to a ramp that switches back 180 degrees.

4.2 Gates and Turnstiles

It is important to accommodate users who have difficulty with negotiating gates, turnstiles or revolving doors. Typically, a separate means of passage is required that is a minimum of 914 mm [3'0"] wide, and has hardware that is suitable for independent use. Install colour contrasted posts at the sides of gates to highlight the accessible path of travel.

4.3 Ramps

While the code requirements for ramps are the minimum standard, the following design installations also need to be considered:

- have a slip-resistant surface, free-draining surface where precipitation does not accumulate.
- demarcate the leading edges of landings at ramps with a contrasting colour tactile warning strip, as well as at the beginning and end of the ramp.
- keep the ramp slope to 1:16 [6.25%] if possible. Where it is technically non-feasible, keep the ramp slope to 1:12 maximum [8.3%].
- landing slopes should not exceed a 2% [1:50] slope in any direction.
- provide edge protection at ramps that is a minimum 101 mm [0'4"] high.
- a ramp landing should not terminate adjacent a stair landing.
- avoided curved ramps.
- avoid excessively long ramp installations, even with multiple landings that are code compliant.
- provide a second handrail on ramps, typically located at 686 mm [2'3"] above the floor and 229 mm [0'9"] below the second handrail. [Do not compromise code climbability concerns where guards are installed].
- handrails should always return to a supporting post or a wall, to avoid being a pedestrian hazard.
- many people find using steps easier and safer than using a ramp. Hence it is preferable that both steps and ramps be installed in close proximity to each other at required locations.

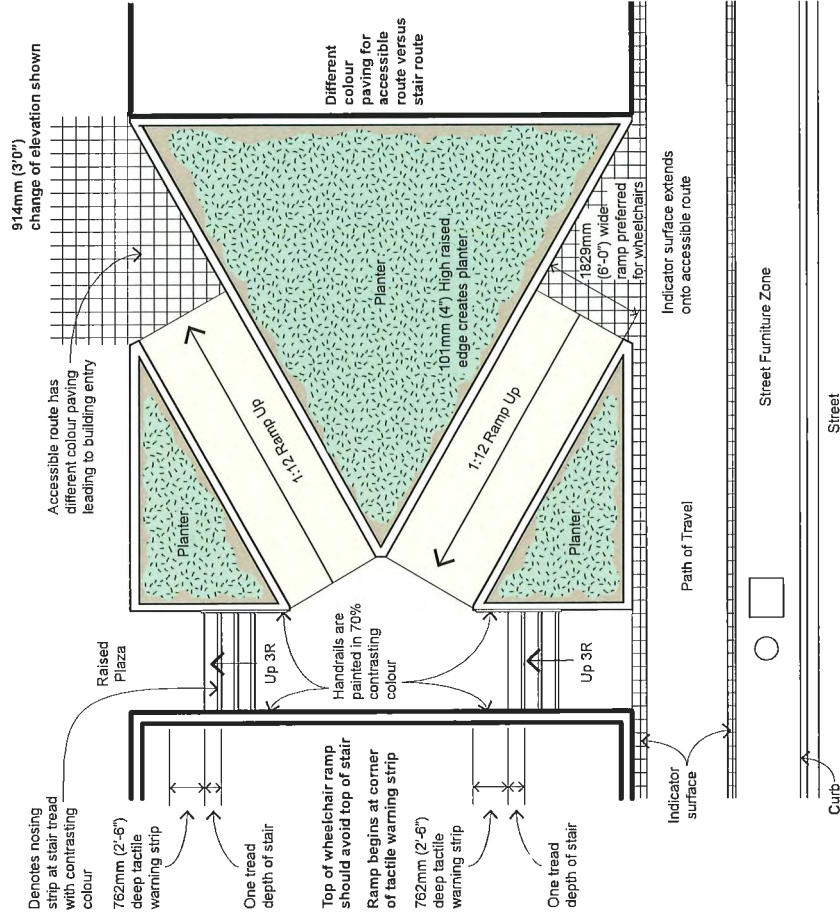

Stair and ramp design at change of level from sidewalk to raised building entry.

4.4 Stairs

As for ramps, the Building Code defines minimum requirements for stairs, but the following should also be considered:

- To assist people who are partially sighted:
- provide high colour contrast for demarcation strips at landings and the leading edges of stairs, and for nosings on stair treads.
 - avoid highly patterned textures on stair treads.
 - ensure stairs and landings have a non-slip surface.
 - stairs should be illuminated to at least a level of 100 lux [9.2 ft.-candles].

To universally assist physical mobility:

- handrails should be circular or ovoid in shape for graspability.
 - ensure handrails have a contrasting colour compared to the adjacent background surface.
 - add a second lower handrail located 686 mm [2'3"] to the top of the handrail above the line of the nosings.
- [Note: check that climbability issues are not created for guards on stairs].
- handrails should be continuous on the inside face of the stair between floors, to ensure that the user's handhold is not broken.
- [Note: avoid newel posts or any obstructions that can break a handhold].

4.5 Colour and Texture

Texture and colour systems should be selected to enhance accessibility:

- avoid heavy or overly distinct patterns on walking paths, floors, walls and ceilings. These can be disorienting to people with perceptual difficulties or partially sighted.
- except for demarcation strips, simple, repetitive, non-directional patterns and low colour contrast in the general material palette is preferred.
- a high contrast colour for baseboards is recommended, to visually emphasize where the floor meets the wall.
- colour should be used consistently, to distinguish important wayfinding elements, such as exit doors, or end walls at the end of corridors (to note a change of direction).
- all textured surfaces that are used as demarcation strips should be cane-detectable. [On interior surfaces, a raised dot or square pattern is sufficient. The use of truncated domes should be reserved for exterior use].
- on exterior pathways, select a material for the path of travel that is non-slip and that contrasts with adjacent surfaces.
- for signs, a glare-free, 70% colour contrast is required to promote visibility. A white/ buff or yellow on a black or dark background is optimal.



River Green Wheelchair Ramp and Stairs.

4.6 Signage

Generally, signage in buildings should be limited to providing essential information to users of buildings and public spaces. Consistently organized and displayed signage enhances usability in buildings for everyone. The use of internationally accepted graphic symbols promotes comprehension and wayfinding, and is helpful for children, those with literacy challenges, and those whose first language is not English.

International Symbol of Accessibility

- should be used at all locations with facilities for individuals with diverse abilities, such as designated parking stalls, accessible entrances and loading zones, accessible toilet facilities, and areas of rescue assistance (areas of refuge).
- generally, if pictograms are used, equivalent verbal descriptions should also be included.

Design Requirements for Signage

- for lettering, avoid stylized, italicized, or fonts with serifs. Arial font is preferred.
 - numbers should Arabic.
 - ensure widths and heights of letters and numbers are sufficient to enhance readability. Avoid the use of capital letters alone, as lower case letters are typically easier to read.
 - backgrounds of signs to be glare-free (eggshell finish preferred).
 - colour contrast to be a minimum of 70% between sign characters and background.
- [Refer to CNIB Guide to Effective Colour Contrast].
- where signs are required to be tactile, letters and numbers should be raised 0.8 mm [0'1/32"] minimum, and not be sharply edged, and be between 16 mm [0'5/8"] and 50mm [0'2"] high.

The Canadian National Institute for the Blind [CNIB] publishes "Clear Print Accessibility Guidelines" that are a useful resource for signage colour and design.

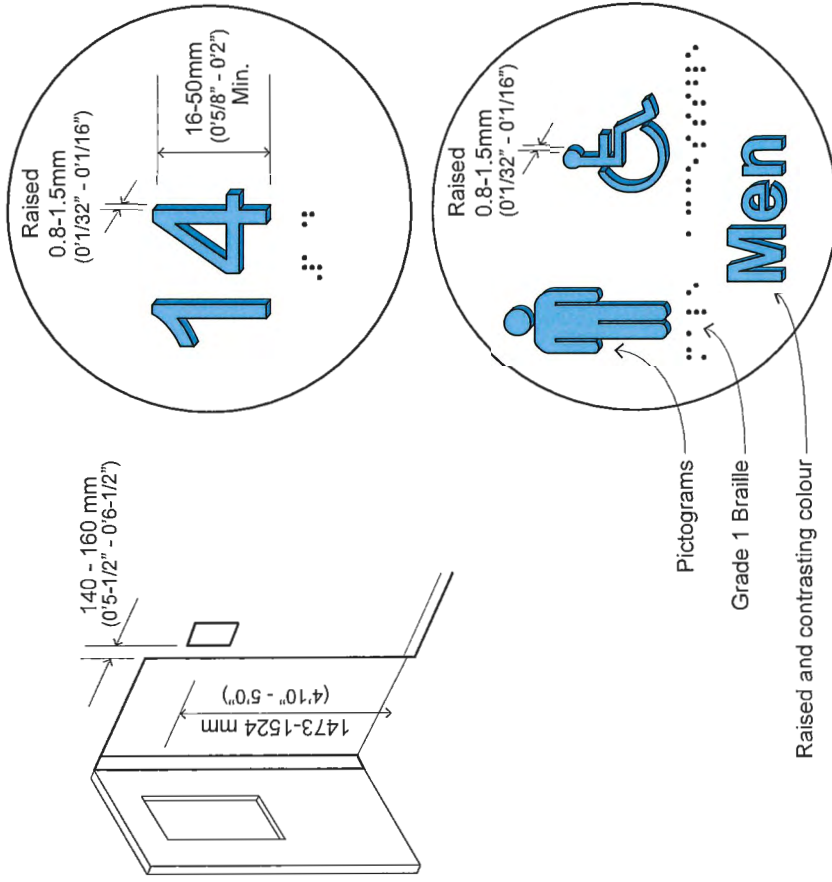

Tactile lettering is the preferred means of signage to enhance accessibility for door or interpretive signage.

- Information Systems and Panels, Display Kiosks, and Video Display Terminals**
- information panels should be inclined, and allow for knee space underneath for ease of reading.
 - provide an alternative format when video display terminals are used, such as audio, Braille and large-text print.
 - ensure push buttons or other controls are mounted at an accessible height.
 - avoid vertical wording or electronic scrolling signage. Where scrolling signage must be used, a slower scrolling speed should be used.
 - consider incorporating digital and communication technologies that aid wayfinding for persons with diverse abilities

4.7 Spatial Requirements at Drinking Fountains and Bottle Fillers.

Generally, it is preferred that two types of fountains be installed:

- a higher one that provides for use by individuals that have difficulty bending.
- a lower one that is more suitable for use by children, or persons using a wheelchair.

Fountains and bottle fillers should:

- be located in an alcove, out of the path of travel, especially if they are wall-mounted above the height of cane-detection.
- have an operating system that accommodates limited hand strength or dexterity. Controls should be on the front of the unit or on both side and front.
- have spouts that are at the front of the fountain, and with a water trajectory parallel to the front of the fountain.

NOTE: Ensure informational/interpretive panels do not have sharp edges

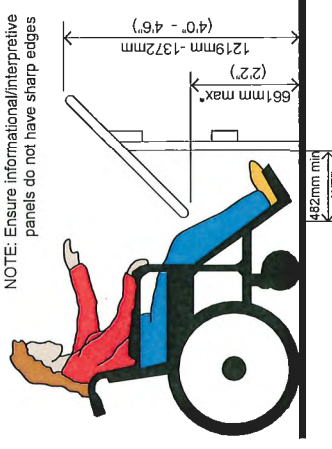

* If sign is legible from 762 mm (26") or further, clearance can be lower with a minimum toe kick clearance of 229 mm (9")

Information Systems and Panels, Display Kiosks and Video Display Terminals should be designed to accommodate accessibility for people with diverse abilities.

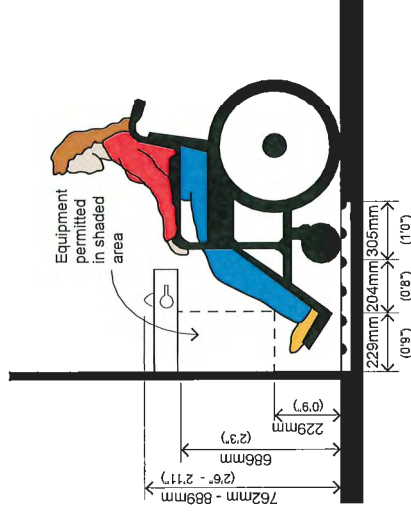

At least one Drinking Fountains and Bottle Filler should be provided, along with one regular height fountain, that allows for access for children and for people with diverse abilities.

4.8 Clearances at Mailboxes and Vending Machines

Generally, provide for space at these elements that allow for maneuverability for wheelchairs and other mobility aids:

- locate these adjacent to a path of travel, and not encroaching into the accessible travel route.
- the highest operable part of the subject element should not be located more than 1219 mm [4'0"] above the finish floor or ground surface, and not below 405 mm [1'4"].

4.9 Waiting, Queuing and Seating Areas

Waiting and queuing areas should provide enough space for mobility devices, such as strollers, walkers, wheelchairs, power wheelchairs and scooters, especially at corners or where queues double back on themselves.

Additionally:

- provide rigidly-mounted handrails to provide support for waiting persons.
- avoid rope-queuing systems, as these are a hazard to persons with who are blind, deafblind or partially sighted.
- provide intermittent seating opportunities for people in waiting areas, or along long routes.
- seating should be located outside the path of accessible travel, at a height that facilitates sitting and rising. Similarly, provide armrests to assist sitting and rising. Seats with backs are preferred to ledge seating, but where ledge seating is provided, say on top of planters, the ledge should have a pitched surface for drainage, and a heel space to promote ease of getting up.
- where picnic tables are provided, it is preferred that all tables have an extension of the table surface to provide knee space for persons in wheelchairs.



Public Seating is Set Back from the Accessible Path.

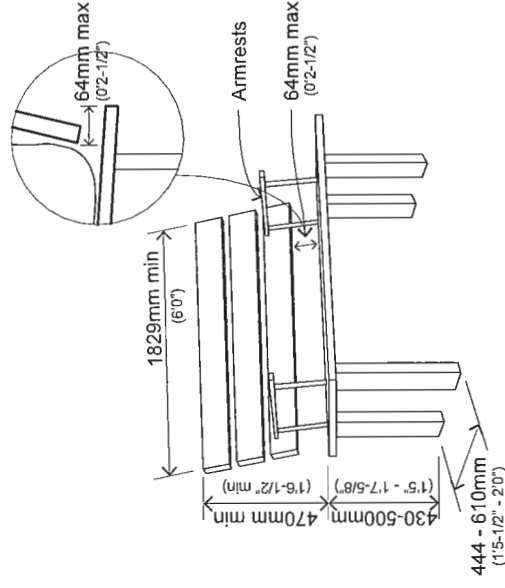

Preferred Bench Dimensions for Enhanced Accessibility.

4.10 Interior Finishing

4.10.1 Flooring

The selection of an appropriate flooring material allows for the safe and easy movement of people using mobility aids, as well as people who are partially sighted.

- floor finishes should be stable, firm, non-slip and glare-free.
- carpet or carpet tile should be low profile, directly glued to the subfloor. Avoid separate underlay, and do not use carpet on ramps.
- if possible, specify carpet that has been off-gassed prior to installation. Off-gassing from new carpeting can adversely affect people with environmental sensitivities.
- avoid heavily patterned flooring. If tile or stone is used, the product should be large in size to minimize joint grout lines, and the finish should not be slippery, too uneven or rough, and not produce glare or reflections. Non-slip, low luster or matte finishes are preferred.
- keep joints in flooring narrow, 6 mm [0'1/4"] maximum. Flooring should be flush on either side of the joint.
- while it is preferable to pick up any variations in finish floor elevations at the subfloor level in order to get flush transitions from one flooring material to another, the use of transition strips is sometimes unavoidable. Such strips should be wider and more gradual, and rated for wheelchair accessibility.



Accessibility is enhanced at elevators by providing a contrasting floor colour to delineate the accessible path. Similar flooring contrasts should be considered to delineate the path to entrances, or other strategically important pathways.

4.10.2 Walls

Interior wall finishes should typically be smooth and have matte or satin finishes to reduce glare:

- more neutral colour palettes are recommended. Avoid patterned finishes.
- avoid any rough surfaces, especially with the use of specialty finishes like wood, stone or feature wall tiles.
- in high traffic areas, some types of impact resistant wainscoting is recommended, again with a smooth finish.
- where keyed access hatches are required to access all in-wall service shut-offs or valves, or similar service items, paint these out as per the colour of the wall.
- handrails along the length of public corridors is recommended.
- for people who are partially sighted, a high contrasting colour baseboard or vinyl cove base is preferred.
- do not obstruct the path of travel with projecting obstacles. Amenities like water fountains should be recessed in an alcove rather than projecting into a corridor.



Generally speaking, neutrally coloured resilient flooring, without excessive patterning, is preferred for flooring in public areas.

4.10.3 Ceilings

- provide a floor-to-ceiling dimension that is appropriate for the space involved. Larger floor areas should have higher floor-to-ceiling dimensions. Allow for floor-to-floor dimensions that permit a ceiling service space of at least 610 mm [2'0"], or more if service requirements in the ceiling space are considerable. Do not design floor-to-ceiling dimensions such that the finish space feels compressed.
- ceilings with exposed services can work if it is appropriate for the subject interior space location. Exposed services and ducts should be thoroughly painted out the same as the exposed structure, to lessen visual clutter in the ceiling space.
- more neutral colour palettes are recommended for finished ceilings. Avoid patterned finishes. Refer to City of Richmond Standard Paint Colour palettes.
- if ceiling drywall is used, it should be limited in the area, with access hatches provided at all required service locations.
- acoustic T-bar ceilings are preferred, with a tile that is simple in texture and pattern.
- Select T-bar lighting systems that provide an even distribution of lighting and do not project any glare.

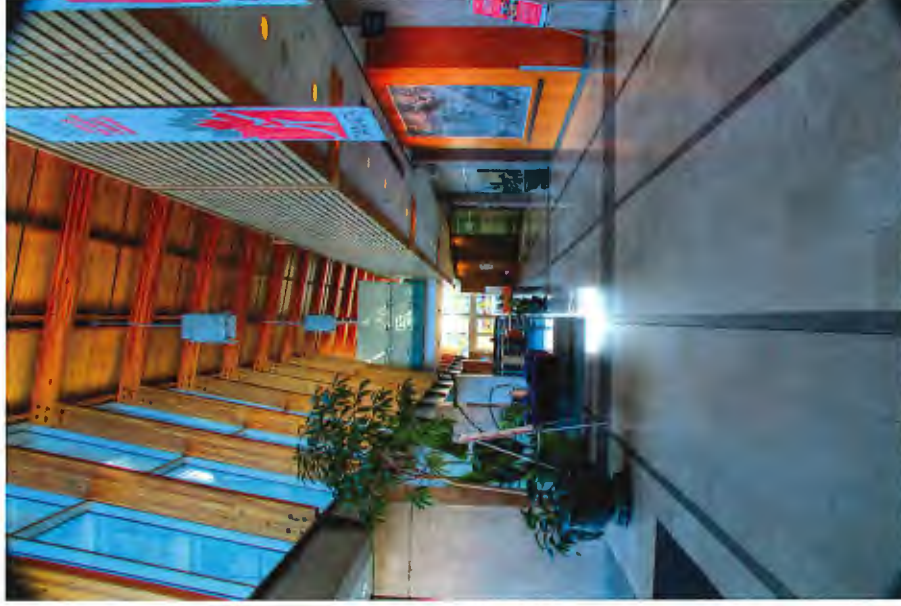

The disorienting effects of glare in public lobbies and hallways, can be reduced by using appropriate interior finish materials, and limiting adjacent large areas of glazing to north-facing exterior walls, as shown in this photo.

4.10.4 Doors and Entrances

Doors

Doors should function in order to maximize independence of use. Reliance on assistance from others in order to negotiate doorways is not an appropriate design strategy:

- ensure doorways are sufficiently wide and high. A 914 mm [3'0"] wide x 2133 mm [7'0"] high doorway is preferred.
- consider the use of 1000 mm [3'3"] doors, in order to have a finished door width of 914 mm [3'0"].
- if double doors are used, avoid the use of a centre post.
- avoid any raised thresholds over 6 mm [1/4"] in height.
- door mats should be fully recessed, flush with the finish floor level, and firmly affixed to the subfloor. (Occasional door mats for use in bad weather should have gently beveled edges).
- if glazed doors are provided, install a colour contrast strip across the glazing at eye level, to assist those with vision challenges. Colour contrasting door frames and door hardware are also recommended.
- automatic door openers provide independence, but these should include an emergency push bar release and battery back-up to ensure operation during power outages.

Automatic openers should be used at:

- building entrances.
- at least one washroom for each gender that includes an accessible toilet stall (unless the facility is doorless).
- accessible individual washrooms or toilet rooms.
- accessible change rooms.
- intermediate doorways across primary circulation routes within a building.

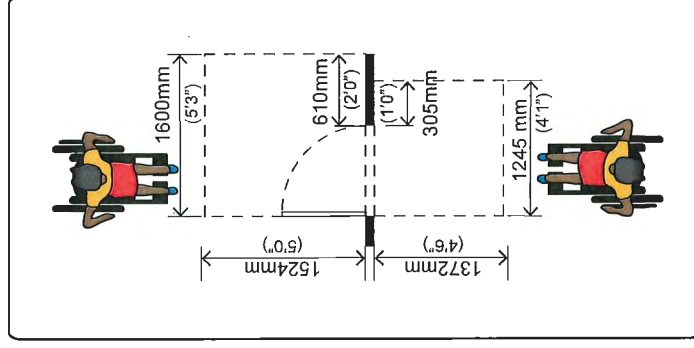

Front approach at hinged doors.
[at top of ramps landing should be 2438 mm x 2438 mm min (8ft x 8ft)].

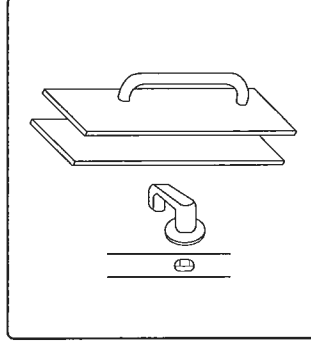

Example of accessible hardware.

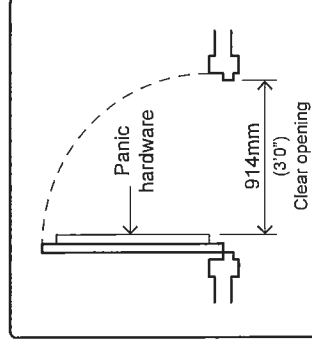

Minimum clear opening at doors.

- provide level wheelchair maneuvering space on both sides of doors, and clear space at the latch side to the adjacent wall, distance dependent on the swing of the door.
- the minimum space between doors in a series is 1524 mm [5'0"], plus the width of the door leaf.
- door operating hardware should be lever type, with the lever bent and returning towards the door surface. Operating hardware should not require tight grasping or twisting of the wrist to operate, and should be installed no higher than 1092 mm [3'7"] above finished floor.
- provide a smooth, uninterrupted 305mm [1'0"] high kick plate on all doors providing access.
- the maximum door opening force should be:
 - 38 N (8.5 lbs.) for exterior hinged doors.
 - 22 N (4.6 lbs.) for interior hinged doors.
 - 22 N (4.6 lbs.) for sliding or folding doors.
- door closers should be adjusted to the least pressure possible, but never more than the door opening forces noted above. The sweep period of the closer should be set so that from an open position of 90 degrees, it should take no less than 3 seconds for the door to move to a semi-closed position of 12 degrees.
- power-assisted swinging doors should:
 - be adjusted to take not less than 3 seconds to move from the closed to the fully open position, and remain fully open for a minimum of 5 seconds.
 - be equipped with a sensor, that stops the door from closing on a person or object that is still in the area of the door swing.
 - require a force of not more than 66 N (13.8 lbs.) to stop the door movement.

Entrances

Entrances should be designed to create an inclusive sense of welcome, and address the widest possible range of a person's physical abilities. The intent should be to promote independence for all users, and not to create separate accessible entrances to meet specialized needs.

- make the place of entrance as obvious as possible.
- install entry canopies and weather protection at main entrances.
- provide required spatial clearances at doors and between series of doors.
- provide automatic door openers.
- provide appropriate intercom communication and electronic security measures.

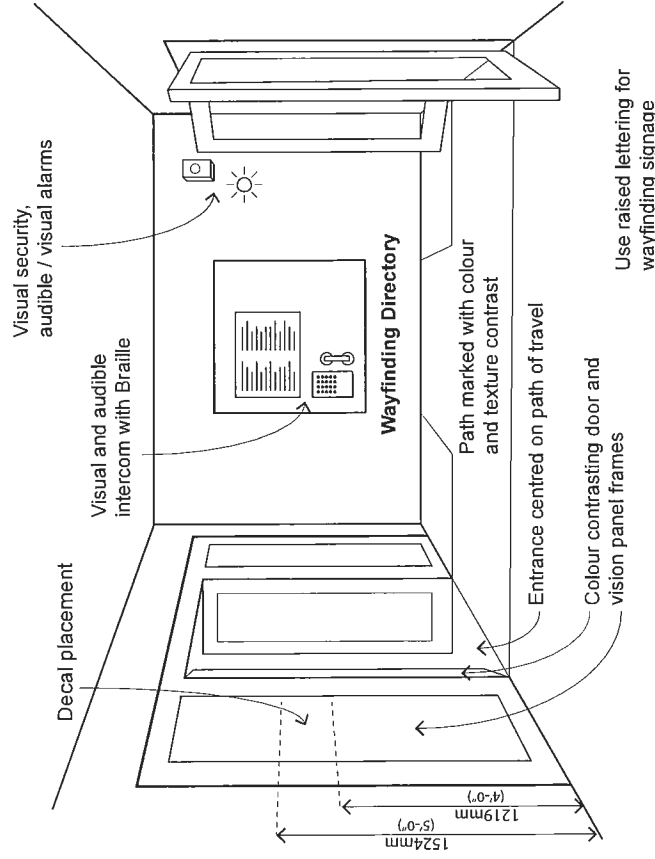

Entry Foyer Considerations.



General Design Considerations to Enhance Accessibility

4

4.10.5 Windows, Glazed Screens and Sidelights

Extensively glazed areas can create perception difficulties for persons who are partially sighted. As noted previously, perception problems relating to where the glazing is actually located can be alleviated by installing rows of decals, typically at 1219 mm [4'0"] and at 1524 mm [5'0"] above the finish floor on the glazing.

Additionally, persons using wheelchairs or scooters experience building interiors from a lower eye level. Lower sill heights and easily reached and operated opening mechanisms on windows are recommended.

CNCL - 265

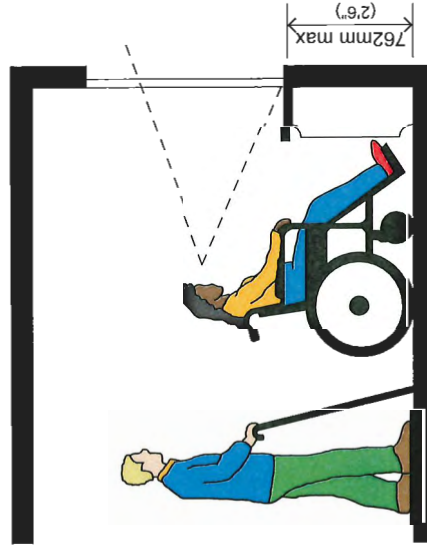

Preferred window sill height.

4.10.6 Reception and Information Counters

A choice of counter heights is recommended to provide a range of options for visitors and staff using Reception and Information Services in a building.

- provide a lower section which allows children, persons of lower height and persons in wheelchairs to receive or deliver Reception services. Ensure that knee space is provided for wheelchair users.
- other sections can be made higher to provide a sense of security and visual privacy for staff at Reception services.
- provide strong colour contrast between counter surfaces and adjacent finishes to give visual clues to people who are partially sighted.
- if additional security measures such as security glazing is required, ensure that speaking ports intended to serve persons in wheelchairs are installed no higher than 1067 mm [3'6"] above the finished floor.



Reception Desk with Accessibility Counter.

4.10.7 Elevators, Lifts and Escalators

Elevators are key in providing independence of movement to persons using mobility aids, and to those with vision challenges. Elevators also provide access for emergency responders, and the car by code, must be sized allow emergency personnel to maneuver a stretcher in the car space.

Elevator car controls should be correctly positioned to facilitate independent use by all people, including those using mobility aids and those who are blind, deafblind, or partially sighted:

- lighting should provide 100 lux (10 ft.-candles) illumination minimum in the car, on the control panels, and at the landing on each floor.
- a verbal audible message identifying the floor landing, and the available direction of travel, should be announced when the elevator stops at a floor.
- mirrors should not be used as a wall finish on the wall opposite the elevator door.
- elevator doors should have a strong colour contrast from the walls in the elevator car, and from the walls adjacent the elevator doors at landings. There should also be a pronounced colour contrast between the car sill, and the adjacent flooring in the car and the landing adjacent.
- consider the use of "smart" elevator call systems, that provide controls with accessibility user features, which allow for customized elevator travel use.

Platform Lifts and Stair Lifts

Typically these should not be used in place of an elevator, but there might be retrofit or heritage reasons why such vertical transport aids should be used in existing buildings. If such lifts must be used, they should be sized to accommodate scooters, as well as a person in a wheelchair with an attendant.

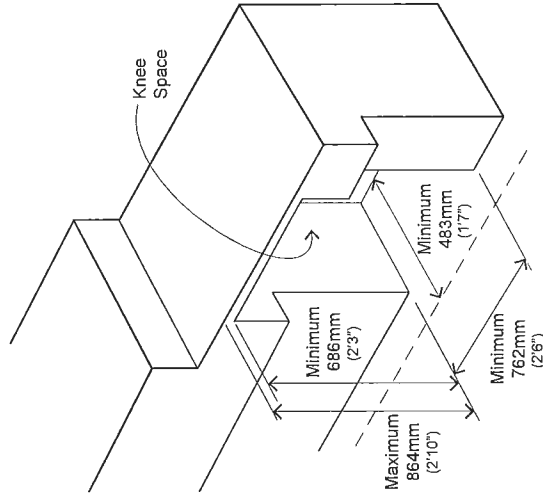

Dimensions for Accessible Reception Counter.

Escalators

Boarding and stepping off of an escalator can be a challenging experience for many people. To enhance safety of escalator use, the following aids are recommended:

- provide high colour contrast strips on escalator nosings and tread edges.
- provide a detectable warning strip at the head and foot of the escalator, similar to those required at flights of stairs.
- provide lighting over escalators at a minimum of 200 lux (18.4 ft.-candles), from a low-glare lighting source.

4.10.8 Work Stations and Shelving

Provide a range of work space counter heights and shelving options for work stations to accommodate a range of user needs and abilities.

- for persons in wheelchairs, provide a maximum height for work surfaces of 864 mm [2'10"]; however, 762 mm [2'6"] is preferred. The minimum height under the work surface should be 686 mm [2'3"], with 509 mm [1'8"] minimum of knee space.
- floor shelving that is meant for use by persons in wheelchairs should have the lower shelf a minimum of 229 mm [0'9"] off of the finish floor, with the top shelf 1372 mm [4'6"] maximum above the finish floor.
- cabinet fronts should have a contrasting colour from the work surface and hardware should be selected that provides for ease of grasping and use with one hand.

4.10.9 Staff Kitchenettes

Staff Kitchenettes should provide adequate maneuvering space and counter, storage cabinet and appliance selection and layout to accommodate persons using mobility aids, particularly wheelchairs:

- provide for a minimum of 1119 mm [3'8"] clearance between the Kitchenette and opposite wall or other counter space.
- provide a counter top that is a maximum of 864 mm [2'10"] above the finished floor.
- provide a portion of the counter top with knee space that is a minimum of 762 mm [2'6"] wide, and provide knee space at the kitchenette sink.
- provide for pull-out drawers rather than shelving in base cabinets.
- if a dishwasher is provided, allow for a clear space adjacent the open dishwasher door.
- microwaves should sit on the countertop, and be reachable for the wheelchair user.
- refrigerators with a lower pull-out freezer compartment are preferred, rather than those with upper freezer cabinets, or side-by-side fridge and freezer doors.
- all kitchen elements should have strong colour contrasts to differentiate the cabinets, counters and appliances from the adjacent wall and floor surfaces.

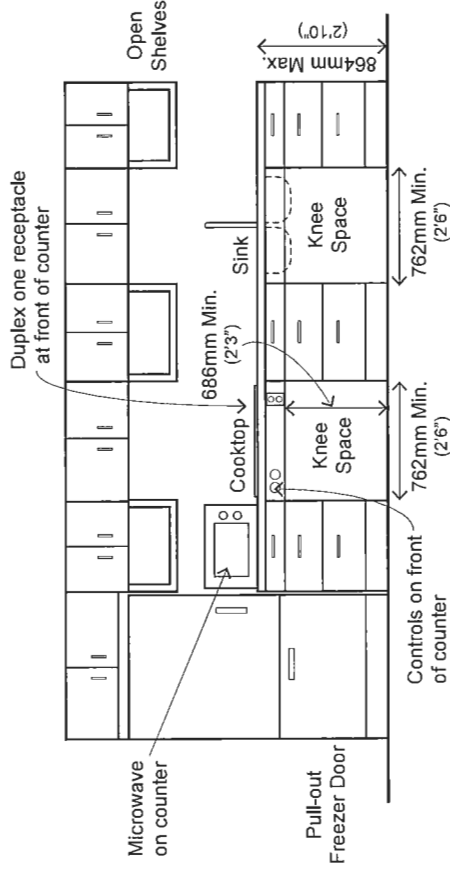

Staff Kitchenette - Elevation.

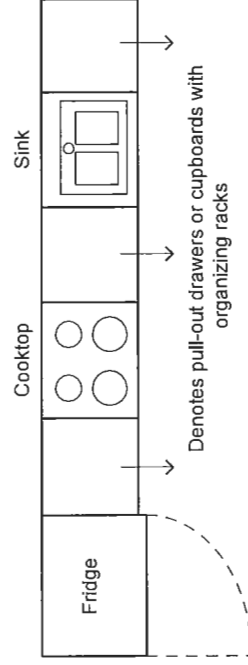

Staff Kitchenette - Plan.

4.10.10 Washroom Facilities

Washroom facilities should accommodate the range of physical abilities of people who will use public buildings. The Building Code sets out minimum standards for accessibility in washroom design, however these requirements do not provide for the wider range of users in buildings; additionally, more space is typically needed to accommodate the use of mobility aids, such as power wheelchairs:

- sometimes gender-specific washrooms create awkward situations where washroom assistance is required. In such cases, providing Universal Washrooms that also function as Family Room Washrooms, in addition to Male and Female Washrooms, is recommended.
- wet floor surfaces in washrooms can increase the risk of falls; therefore an emergency call switch is recommended in accessible toilet stalls.
- strong colour contrast is recommended for elements in the washroom, to assist users who are partially sighted.
- if space allows, it is preferable that doors to washrooms be eliminated by means of open vestibules that provide for visual privacy.
- where doors into washrooms are provided, automatic door openers / operators should be installed.
- infant change tables should be provided in all washrooms.

Typical Male and Female Washrooms

Even if a Universal Washroom is provided, accessible facilities are still required in these General Use Washrooms. Extra space should be included in these washrooms, beyond the requirements of the Building Code, to allow for user movement with mobility aids and for assistance by attendants.

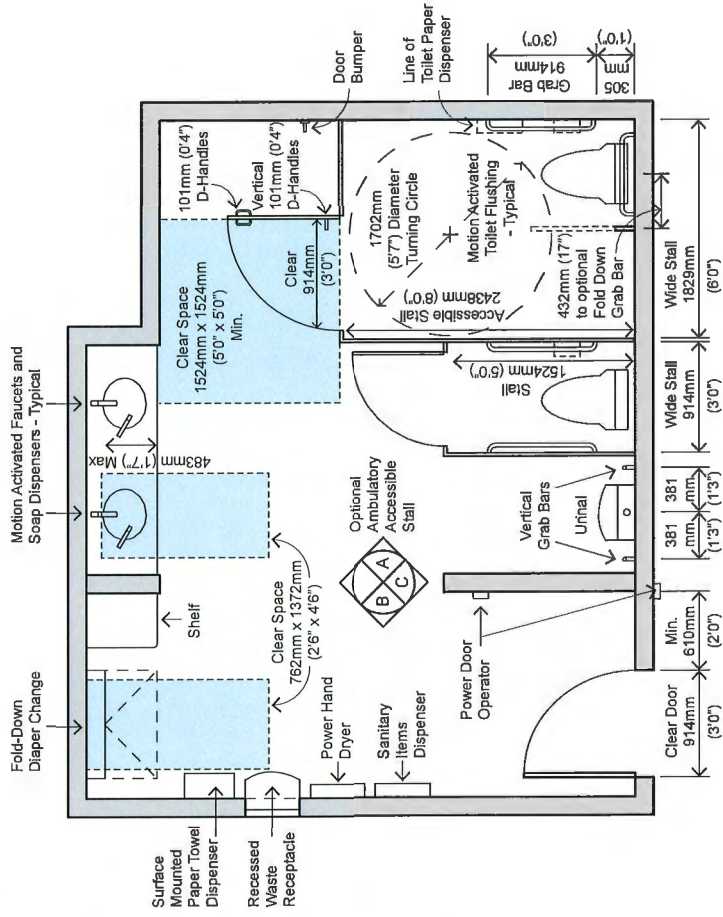

Typical Accessible Washroom - Plan.

General Design Considerations to Enhance Accessibility

4



Elevation A
Downlight Over Sink

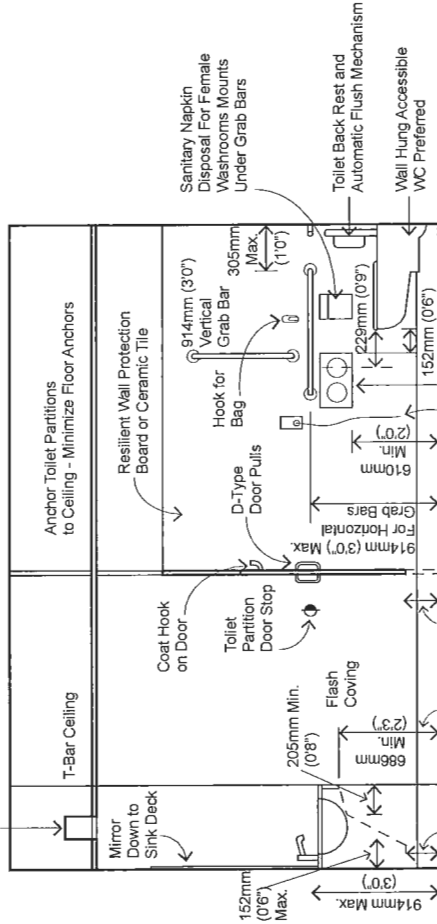

Elevation C
Toilet Partitions Supported From Ceiling Structure

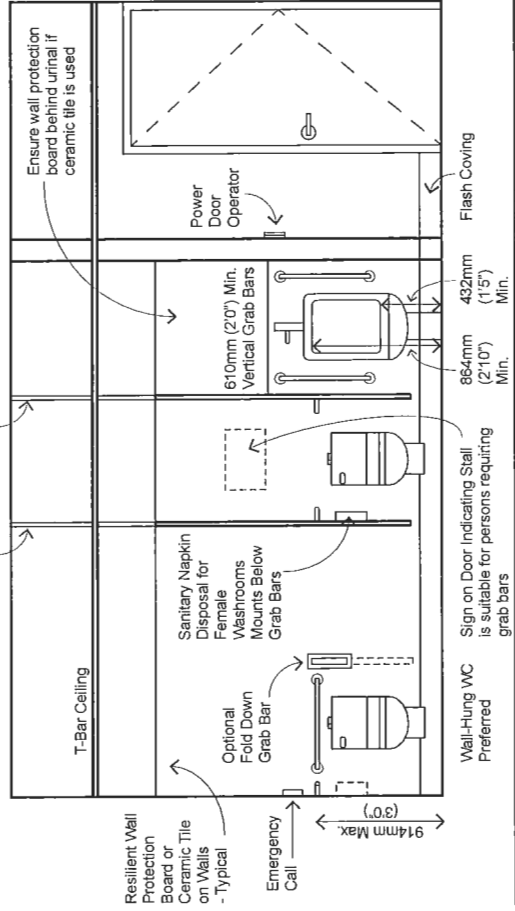

Elevation B

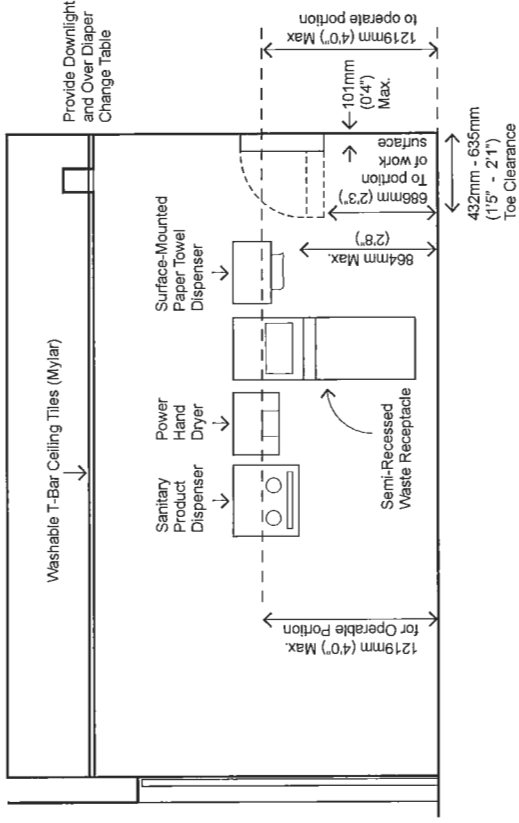

Universal Washroom

One Universal Washroom should be provided on each floor, in addition to Accessible Male and Female Washrooms:

- provide an emergency call switch.
- the Universal Washroom should be equipped with a door that is capable of being locked inside with one hand, and which has a lock that can be released from the outside by authorized staff in case of emergency.
- a change bench for the user is recommended, that is at least 762 mm [2'6"] deep x 1829 mm [6'0"] long.

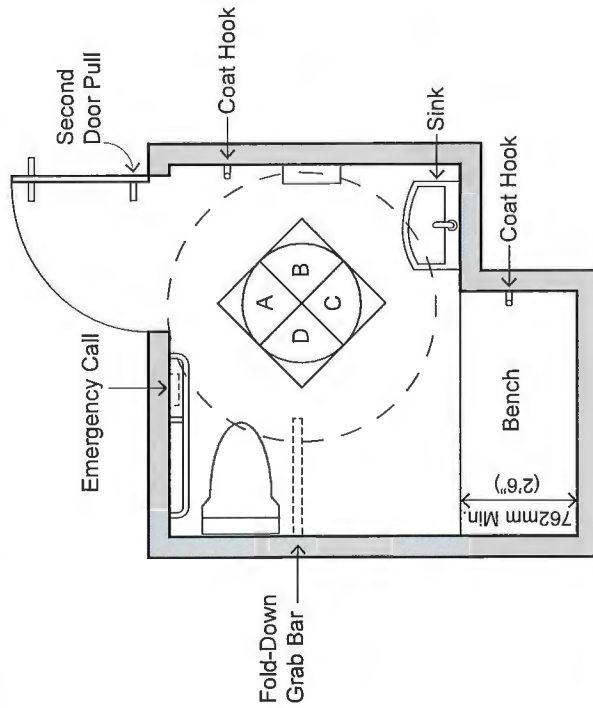

Universal Washroom - Plan.

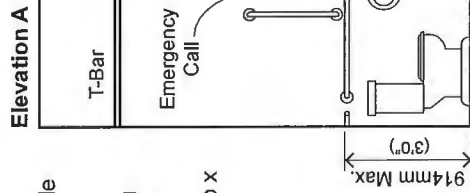

Elevation B

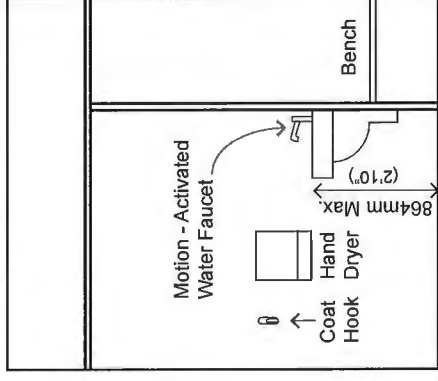

Elevation C

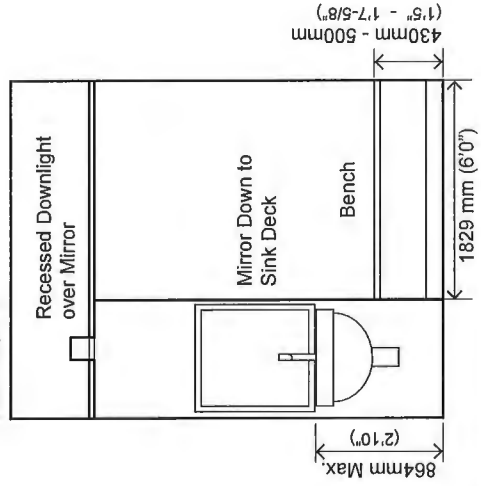

Elevation D

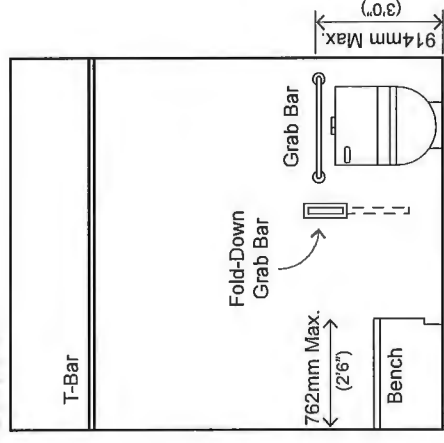

Shower Stalls

When showers are installed for use by staff in buildings, the shower stalls provided should be accessible, and incorporate low thresholds, hand-held shower wands, and seating benches.

Additionally:

- shower valves should be equipped with thermostatic mixing valves that limits the hot water temperature to 49 degrees C [120 degrees F].
- enclosures for shower stalls should not obstruct controls or the ability to transfer from wheelchairs onto shower seats.

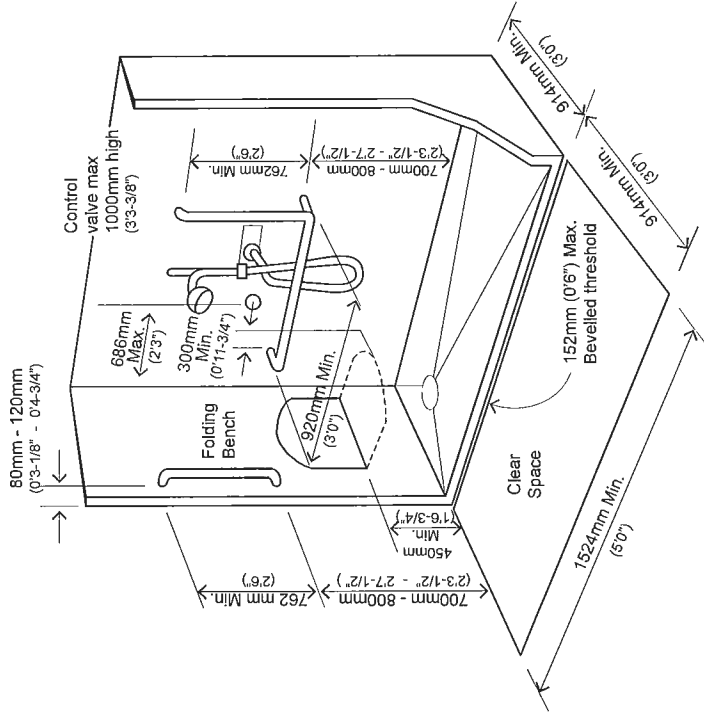

When shower stalls are installed for use by staff in City-owned buildings, the shower stall should be an accessible one.

4.10.11 Lockers and Storage Areas Lockers

Accessible staff locker areas should be provided for 20% of staff.

- the bottom shelf of a locker should be no lower than 405 mm [1'4\"] above the finish floor.
- the top shelf should be no higher than 1372 mm [4'6\"] above the floor.
- the locking mechanism for the locker should be mounted no higher than 1067 mm [3'6\"] above the floor.
- locker numerals or names should be in clearly legible raised lettering, and in a contrasting colour.

Storage Areas

Provide for a minimum of 1372 mm [4'6\"] for aisle spaces in front of storage shelves [and lockers].

4.10.12 Controls and Operating Mechanisms

The placement of controls is integral to their accessibility:

- install controls so that they accommodate the reach of persons in wheelchairs.
- provide controls that contrast in colour from their background, and provide tactile markings to assist people with vision impairments.
- plumbing controls should generally be electronically controlled, however if hand-operated controls like faucets are provided, these should be operable by one hand without the need to grasp tightly or twisting of the wrist.

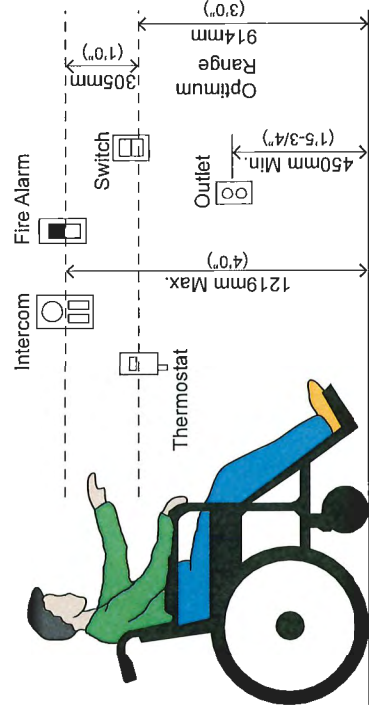

Reach range for accessible controls.

4.10.13 Emergency Exits and Areas of Refuge

In the event of fire when elevators cannot be used, areas of refuge (areas of rescue assistance) are provided by code in protected floor areas at floor landings in stairwells.

- provide additional space between the door jamb and the leading edge of the stair, beyond that which is required by code.
- provide a two-way voice communication system for use between the area of refuge and the central alarm and control facility.

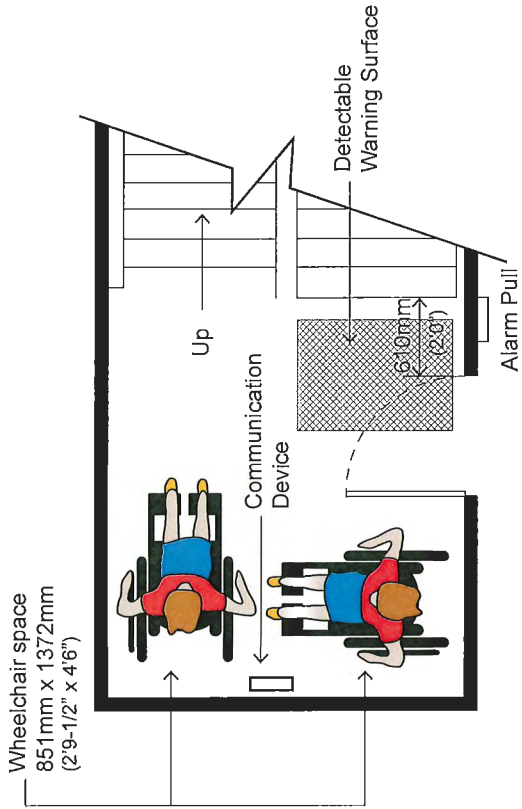

Area of refuge assistance.

On the ground level outside of the building, it is recommended that a gathering or refuge area be located, to allow for people with physical or cognitive challenges to wait in an emergency, in a relatively safe place until help arrives.

Such a refuge area would ideally be linked with the building exit by a clearly demarcated path, with a handrail situated on the path edge leading to the refuge area. The refuge area could also be developed as a seating area for everyday pedestrian use.

4.10.14 Security Considerations and Alarms Emergency Signaling

To provide an added sense of security for more frail seniors or persons with diverse abilities who are using building facilities, adequate lighting and emergency signaling devices are important considerations in building design:

- as noted previously, provide sufficient lighting along public walkways, steps and ramps.
- provide emergency signaling devices in locations like washrooms, where the potential for a fall may be increased and an individual may be alone.

Security System Access

- when card-access systems are used, all system components should be suitable for persons of varying abilities.
- intercom entry systems should provide both visual and verbal features, to accommodate persons with vision, hearing or speech challenges. These include providing both audible (beep) and visual (light) signals to indicate that access has been granted.

4.10.15 Indoor Lighting Considerations

Artificial lighting and natural light typically should provide a glare-free and evenly distributed light where required, at working areas, on accessible path routes, at areas of potential hazard, and at building entrances.

Indoor Lighting Principles

- typically, light fixtures should be selected to minimize glare. Avoid wrap-around lenses and install fixtures that employ diffusers or are recessed. Provide for general, even distributed levels of illumination, and task lighting at work stations.
- use curtains, blinds or other sun-screen elements to modify direct sunlight exposure.
- select interior material finishes that generally do not create high-gloss reflective surface effects.
- provide illumination at the surface level of stairs, ramps and landings of at least 50 lux.
- operating portions of control devices should be illuminated to a level of at least 100 lux, and where reading is necessary, to a level of 200 lux.

4.11 Streetscape Considerations

All on-site parking areas and sidewalk and street design elements within 3047 mm [10'0"] of City-owned buildings should be designed for greater ease of accessibility:

- avoid slippery surfaces, or irregular surfaces, such as cobblestones or gravel that are difficult for walking or wheelchair use.
- avoid openings in grates or grilles that can catch high heels, canes or wheelchair wheels. (A maximum width of opening should be limited to 13 mm [0'1/2"], with the opening at right angles to the path of travel).
- if boardwalks are installed, a handrail along the length of the boardwalk is recommended.
- avoid surface materials that are prone to differential settlement, and which can develop trip hazards. Surface materials should be installed on a stable sub-base that is not susceptible to frost heave or other vertical movement.
- ensure that all accessible routes have a smooth, firm and solid surface, free of obstructions like streetlight and traffic signal standards and poles, street trees, waste receptacles, newspaper boxes, benches, outdoor patios or bus shelters.
- for the sight challenged, demarcation strips to signal the presence of such street furniture is required.
- all street elements that serve the public, like push button signal controls or flaps on waste receptacles or mailboxes, should be installed at a height that serves accessibility for all users.
- curb ramps should have a wide and smooth transition from a travel path or a sidewalk to the street finish elevation at a crosswalk. Truncated cones required in designated pedestrian zone areas so that people with vision challenges can safely negotiate the curb ramp.

- [Refer to City of Richmond Supplement to Master Municipal Construction Standards].
- contrasting paving strip should be installed at open plazas to allow for a partially sighted person to safely negotiate from the path of travel/sidewalk to the entry of a building.

- shrub plantings at landscaped areas should not encroach into the path of travel, and plant material should be selected that minimizes potential obstruction of the accessible path with excess leaf droppings or seed pods. Thorny shrubs also should be avoided directly adjacent the path of travel. Some plant materials that provide olfactory clues for the sight challenged can be considered, to promote wayfinding independence.
- overhanging tree branches should be cut back to provide a minimum of 2438 mm [8'0"] clearance over the path of travel.
- dog parks or dog relief areas should not encroach on the accessible path of travel, and should feature a waste receptacle that provides for accessible use.

The clear path of travel is typically a minimum of 1524 mm (5'0") in width, and 1981 mm (6'6") in pedestrian-oriented areas as noted in the Richmond Official Community Plan

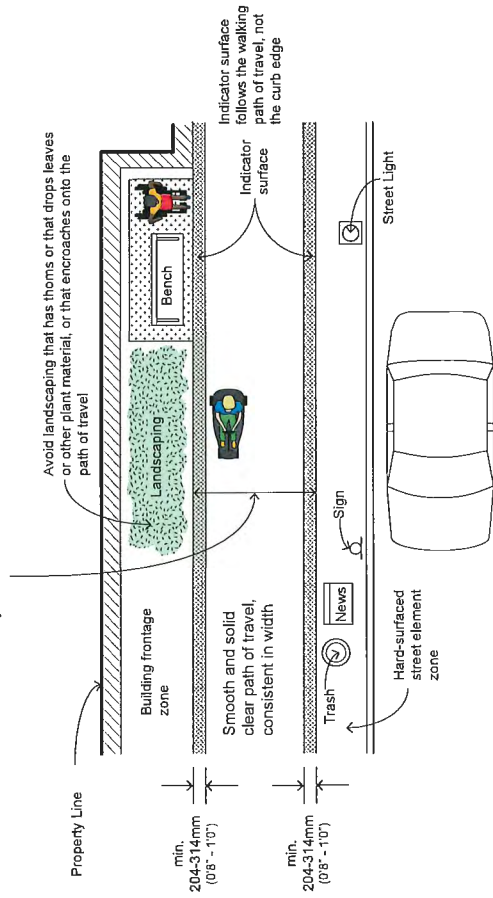

Streetscape element and the path of travel.

4.12 Parking Area Considerations

It is important to provide parking spaces for people with limited mobility close to building entrances, and provide an accessible path that is convenient and safe:

- accessible parking requirements, including van access parking, access aisle and signage per Richmond Zoning Bylaw 8500, Section 7 Parking and Loading
- avoid any steps or curbs.
- in parking areas with angle parking, provide a parking stall as required by the Richmond Zoning Bylaw 8500, Section 7 Parking and Loading, along with an adjacent maneuvering aisle, but also consider enhancing maneuvering space to facilitate ease of mobility.
- where parallel parking is provided, consider the needs of people using mobility aides such as a power wheelchair or scooter, that should utilize a side-loading lift in a van to load and unload the user and the mobility aide.
- ensure signage clearly demarcates that the parking stall is for accessible use.
- ensure that all surfaces on the ground plane are firm and level, with a maximum 2% slope to drain to keep the parking and maneuvering areas free-draining.
- ensure access aisles are clearly marked.
- allow for additional overhead clearance at certain marked parking stalls, to anticipate that some users may be driving vans that are higher than standard height.

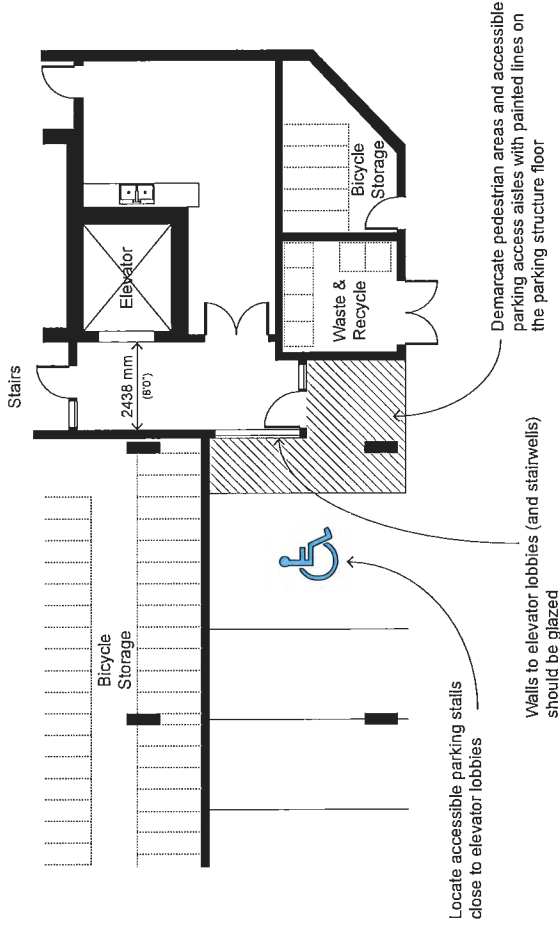

Approaching and entering a City-owned building entry from an under-building parking structure.

4.13 Passenger Loading Zone Considerations

Similar to installing access aisles for accessible parking stalls, passenger loading zones also require maneuvering space to safely and conveniently accommodate users with limited mobility.

Additionally, it is beneficial to provide weather protection, as well as interior or covered exterior waiting areas that have a clear line of sight to the vehicle loading area.

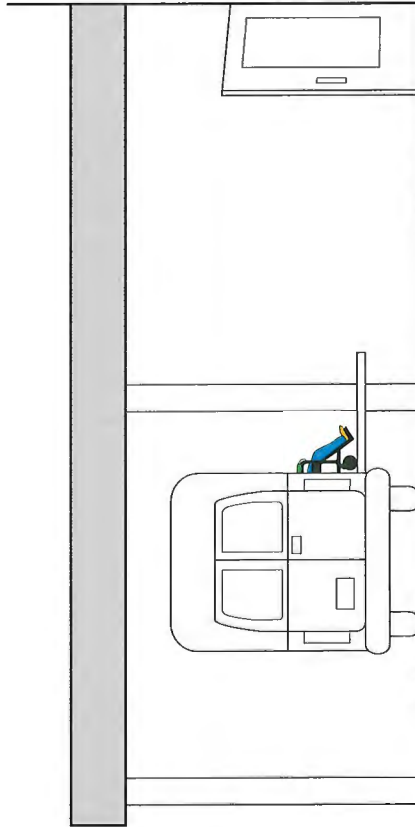

Passenger loading zones require maneuvering space to safely and conveniently accommodate users with limited mobility.

4.14 Outdoor Recreational Facilities

Opportunities for active outdoor recreation should be available to all members of the community, regardless of their level of physical mobility.

Access should be provided to all public facilities, including outdoor areas and washroom facilities located in parks and recreational areas, given Richmond's generally flat topography.

- avoid steps and ramps if possible. Where ramps or elements like footbridges are installed, ideally these should be sloped at no greater than 1:20 [5%], with non-slip surfacing and suitable handrails or guards painted in a colour with good visual contrast.
- on paths, install lighting, waste receptacles, benches, drinking fountains, trees and shrub plantings, and other pedestrian path elements, in a location adjacent and not encroaching on the accessible path.
- ensure bike paths are separate from accessible paths, and that intersections are well-marked, informing cyclists to slow down, and giving the accessible path the right-of-way.
- entrance gates to park and recreational areas should be designed to accommodate accessibility, and spectator areas for people using mobility aids should also be installed at sports fields, incorporating benches and raised viewing areas.
- children's play areas should incorporate features that enhance accessibility, both for adults supervising children's play, and for children who may have limited mobility.

4.15 Drop-Off and Pick-Up Shelters

Platforms for these shelters where buses that deploy a power ramp to accommodate people using mobility aids, should be minimum 3 m x 9 m, and also maintain a clear accessible route for users, free of any obstacles.

It is recommended also that such shelters have at least one higher seat with armrests that accommodate a less mobile user, and all vertical glass elements should be framed, typically in metal, and in a strong contrasting colour.

4.16 Outdoor Lighting Considerations

Similar to indoor lighting, artificial lighting and natural light typically should provide a glare-free evenly distributed light where required, at outdoor working areas, on accessible path routes, at areas of potential hazard, and at building entrances and places of outdoor amenity.

Outdoor Lighting Principles

- illumination along an accessible route should not create any dark or shadowy areas.
- at public entrances, provide a full spectrum type lighting, of a minimum 100 lux (9.4 ft.-candles), measured at the ground.
- at walkways, stairs and ramps, rest areas, and accessible parking areas, lighting levels should be 50 lux (4.7 ft.-candles) measured at the ground. In interior parking garages, the lighting level should generally be 10 lux (0.94 ft.-candles) measured at the ground, with higher lighting levels provided at entrances to building circulation and adjacent areas.
- at passenger drop-off areas, lighting should be 30 lux (2.82 ft.-candles), measured at the ground.
- at steps or stairs, provide lighting directly beside to clearly define the treads, risers and nosings.
- provide supplementary lighting to highlight signage and other orientation elements.



Richmond park path.

5.0 Technical Specifications

5.1 Purpose - Technical Specification References

- to organize the design, construction, material and building system requirements associated with Enhanced Accessibility, into industry-standard specification nomenclature.
- to be used as a tool for preparing cost estimates early in the design process.
- for use by consultants who are ultimately responsible for ensuring that the completed project meets all standards, and conforms to the regulations of all authorities having jurisdiction.

5.2 Technical Specification Sections

- consultants for City-owned building projects should use the following Divisions and Sections annotations in this document, as a basic guideline for the formulation of construction specification document packages accompanying construction drawings.
- specification packages will vary from project to project, and will be the consultant's responsibility to ensure that the specification requirements adequately describe the scope of work associated with the specific project.
- the following specification references are organized according to the Masterformat Specification System.
- please refer to the City's "Building Facilities Design Guidelines and Technical Specifications" for a more detailed overview of specification considerations for City-owned buildings.

5.3 Outline Specification - Enhanced Accessibility

5.3.1 Overview of New Construction General Design Requirements

- provide designs for accessibility in buildings that respond to user's needs, and that provide durability and that are cost effective in construction.
- respond to the Design Guidelines and Technical Specifications noted in this document.

5.3.2 Overview of Construction Design Requirements for the Renovation of Existing Buildings

- respond to the requirements of the Design Guidelines and Technical Specifications as much as possible.
- review structural engineering and code issues with consultant specialists, regarding incorporating enhanced accessibility design requirements.
- install an accessible elevator in all multi-storey buildings. If there are concerns about how an elevator might be successfully integrated into an existing building condition, consider the inclusion of other elevating devices such as platform lifts, and review with City staff.

5.3.3 Excavation, Backfill and Compaction

- comply with all municipal bylaws and applicable building codes, as well as all Master Municipal Construction Documents, relating to subsurface, paving, and drainage work.
- ensure sub-bases and base course layers receive proper compaction and drainage to provide for durable paved finish surfaces that are not prone to differential settlement and heaving.

Specification Reference - Section 31 00 00 - Earthwork

5.3.4 Exterior Surface Finishes - Hard and Soft Surfaces /Landscaping

- provide exterior surface areas and landscape designs that are simpler in nature and that provide durability and amenity, and that require low maintenance.
- provide parking areas that are required by the City, and that meet accessibility standards.
- select landscaping that does not create hazards for people with diverse abilities, such as thorny bushes adjacent pedestrian paths. Also select plant material that could provide olfactory and orientation clues, such as aromatic flowering trees or shrubs in strategic locations.

Specification References - Section 03 35 00 - Concrete Finishing
Section 31 22 13 - Rough Grading (Landscape)

Section 32 01 90 - Landscape Establishment & Maintenance

Section 32 05 23 - Concrete for Exterior Improvements

Section 32 14 13 - Concrete Unit Paving

Section 32 12 16 - Asphalt Paving

Section 32 17 23 - Pavement Markings

Section 32 91 21 - Growing Medium and Finish Grading

Section 32 93 10 - Trees, Shrubs and Groundcovers

5.3.5 Basic Concrete Materials and Methods

- all floors to be left exposed, or that receive carpeting, resilient flooring, or floor tile, should be finished flat, and free from defects that would telegraph through finish materials.
- provide control joints at required locations to control cracking.
- avoid changes in floor elevation between finished surfaces, by anticipating the depth of floor finishes and accommodating these with different finish concrete substrate elevations, to keep the overall finish flooring level flat and true.

Specification Reference - Section 03 33 00 - Cast-In-Place Concrete

Section 03 35 00 - Concrete Finishing

Section 03 54 00 - Concrete Self-Leveling Topping

5.3.6 Basic Metals Materials and Methods - Miscellaneous Metals

- provide guardrails, handrails and other miscellaneous metal fabrications that meet accessibility requirements.
- the Contractor will retain a structural engineer registered in the Province of BC to prepare signed and sealed shop drawings for metal fabrications.
- finish for miscellaneous aluminum or steel metals should be powder coat paint.

Specification Reference - Section 05 50 00 - Metal Fabrications

Section 05 58 00 - Historic Metalwork

Restoration

[Existing Buildings]

5.3.7 Rough Carpentry

- Floor Underlayment for Finish Resilient Flooring or Carpeting
- provide 3 ply, 9 mm [11/32"] thick spruce plywood with the finish face double-sanded and the back face lightly sanded. Prior to installation, confirm that the finish product will be acceptable to the resilient flooring manufacturer.
- Grab-Bar and Railing Blocking
 - provide 38x235 mm [2x10] typical in the wall framing at anchoring locations for grab-bars, handrails and guards.

Specification Reference - Section 06 10 00 - Rough Carpentry

5.3.8 Finish Carpentry

- workmanship should conform to the Quality Standards for Architectural Woodwork as published by the Architectural Woodwork Manufacturers Association of Canada [AWMAC], latest edition.
- **Casework**
 - AWMAC Custom Grade typical.
- **Wood Cabinets for Transparent Finish**
 - Grade A face veneer, with adjustable shelving veneer plywood core.
- **Plastic Laminate Cabinets**
 - all surfaces P.Lam, with adjustable shelving veneer plywood core.
- **Countertops**
 - "Corian" type non-porous countertops with integral splash.
- **Cabinet Hardware**
 - 101 mm [4"] minimum D-pulls, polished or brushed chrome finish.
- **Wall Protection**
 - 9 mm [3/8"] veneer face plywood is acceptable, as is PVC plastic wainscoting. Provide wood battens or PVC trim strips to avoid flush detailing.
- **Outdoor Wood Furniture (Benches, Picnic Tables, etc.)**
 - smooth sanded finishes. Transparent coatings preferred.

Specification Reference - Section 06 20 00 - Finish Carpentry
 Section 06 20 11 - Landscape Finish Carpentry
 Section 06 40 00 - Architectural Woodwork
 Section 06 42 00 - Restoration of Existing Architectural Woodwork
 [Existing Buildings]

5.3.9 Doors

- typically provide a 914 mm [3'0"] clear opening at doors. [Generally this means a 1000 mm wide door].
- position doors to allow for required clearances at jambs, and approach clearances for wheelchair users.

Specification Reference - Sections relating to Doors

5.3.10 Glass and Glazing - Doors and Windows

- provide frames with strong contrasting colours for glazing in doors and windows, to provide potential obstruction signals and orientation clues for people who are partially sighted. Similarly, provide decals or patterns on glazing at eye level in the standing and seated positions.
- in lieu of tilt mirrors to serve people in wheelchairs, consider wall mirrors that extend down to the deck of the sink vanity or counter.

Specification Reference - Sections relating to Windows and Doors
 Section 08 80 50 - Glass and Glazing

5.3.11 Finish Hardware

- provide lever handles on all passage or locksets. Install pulls with faceplates on non-locking doors.
- provide automatic door openers at entry doors and at selected washroom and universal washroom doors (See Design Guidelines), and at all doors where required clearances at jambs are technically not feasible.
- provide accessible thresholds at doors.
- install electronic and security system hardware at accessible heights above the finished floor.

Specification Reference - Section 08 70 00 - Door Hardware
Division 28 - Electronic Safety and Security

CNCL - 280

5.3.12 Interior Finishes Floors

- provide resilient flooring generally and in wet areas. Vinyl tile or sheet vinyl goods with welded seams are acceptable. Flash coving is preferred in wet areas with sheet goods, in lieu of standard vinyl base.
- if ceramic or stone tile is used, larger size tiles are preferred that are non-slip. Use ceramic base tiles and darker colours for grout.
- carpet tile is a preferred product compared to wall-to-wall. Avoid carpet with underlay.
- walk-off entry mats should be recessed in the finished floor, so that finish floor elevations are flush and level. Vinyl transition strips between floor finishes should be rated for accessibility.
- specify flooring materials that do not create off-gassing or negatively affect interior air quality.

Specification Reference - Section 09 30 13 - Ceramic Tiling
Section 09 65 10 - Resilient Flooring
Section 09 65 16 - Athletic Flooring
Section 09 68 00 - Carpeting
Section 10 90 00 - Miscellaneous Specialties
(Walk-Off Mats)

Walls and Ceilings Walls and Partitions

- painted drywall is the typical finish. Avoid rough wall finishes.
- wall protection and corner guard treatments are recommended in high traffic areas.
- provide sound absorptive panels in areas where echo problems could occur.

Ceilings

- typically install commercial quality T-bar acoustic ceilings, with an NRC rating of 70 or better.
- provide washable ceiling tiles in washrooms, kitchens and service rooms.

Painting

- provide paint sheens that are washable.
- refer to City of Richmond Standard Paint Colour palettes for paint colour selection.
- specify paints that are low VOC (volatile organic compounds) and that do not negatively affect interior air quality.

Specification Reference - Section 09 21 16 - Gypsum Board Assemblies

Section 09 30 13 - Ceramic Tiling
Section 09 51 13 - Acoustic Panel Ceilings
Section 09 84 13 - Fixed Sound Absorptive Panels
Section 09 91 10 - Painting
Section 10 90 00 - Miscellaneous Specialties
(Wall Protection, Corner Guards)

5.3.13 Washrooms and Accessories

- Common and Accessible Washrooms

Plumbing Fixtures

- accessible height wall-hung commercial toilets with padded back rest. Alternately (review with Richmond staff), accessible height tank style WC's with bolted tops.
- self-rimming drop-in sinks in accessible vanities with accessible type motion-activated plumbing brass. (Preferred compared to single wall-hung sinks).
- wheel-in showers where required. (For example, in staff rooms).

Washroom Accessories

- all accessories to be rated for accessible use.
- annealed finish on grab bars.
- hand dryers are preferred to paper towel dispensers. If paper towels are used, provide recessed accessible towel and waste containers, or an under-counter receptacle with a wide diameter grommet opening in the washroom countertop.

Lighting

- install at sufficient levels to accommodate use by people who are partially sighted. Provide indirect over-mirror lighting at 100 lux (9.4 ft.-candles) illumination in combination with general room lighting.

Toilet Partitions

- ceiling-hung, with no supports anchored in the flooring. Provide heavy-duty polished chrome or brushed nickel finish on hardware, which should be anchored with tamper-proof screws.

Diaper Change Tables

- typical in washrooms.

Specification Reference - Section 10 21 14 - Toilet Compartments

Section 10 28 14 - Toilet and Bath

Accessories

Division 22 - Plumbing

Division 25 - Lighting

5.3.14 Kitchenettes

Millwork - See 5.3.8 - Finish Carpentry

- plywood construction and "corian" countertop with corners eased.

Plumbing Fixtures

- double bowl self-rimming stainless steel kitchen sinks preferred, in countertops designed for accessible use and maneuvering.

Appliances

- refrigerator with a pull-out bottom freezer compartment is preferred.
- countertop model microwave.
- cooktop with front controls (unless in a location accessed by children).

Specification Reference - Section 06 40 00 - Architectural Woodwork

Section 11 31 00 - Residential and

Commercial Appliances

Division 22 - Plumbing

5.3.15 Staff Facilities

Staff Office

Millwork - See 5.3.8 - Finish Carpentry

Staff Room

- provide Kitchenette as per 5.3.14 over.
- lockers should be accessible.
- provide accessible staff washroom and confirm if wheel-in shower is required.

Maintenance and Storage Areas

- provide maintenance workbench and storage shelves from nominal frame lumber and good-one-side 19mm (3/4") plywood.

Design for accessible use

- storage systems should provide for accessible use.

Specification Reference - Section 06 20 00 - Rough Carpentry

Section 06 40 00 - Architectural Woodwork

Section 10 90 00 - Miscellaneous Specialties

(Metal Lockers and "Interlock" Shelving

Systems)

Division 22 - Plumbing

Checklist for Enhanced Accessibility

With an aging population, and an increasing need to enhance independence for people with physical, sensory and cognitive challenges in everyday life, there is a need to exceed minimum standards for accessibility wherever possible.

Enhanced accessibility in building and open space design, will also benefit all users by offering design solutions to a wider range of functional issues than is typically considered in the design and development process.

Checklist Legend



Physical Access



Blind or Partially Sighted Access



















Deaf or Hard of Hearing Access





Cognitive Limitations Access

1.0 Building Entrances		Notes / Remarks
<p>1.1 Barrier-free paths to entrances are provided and enhanced with designation strips.</p> <p>1.2 No obstructions are located in the path of entry. [e.g. Waste receptacles, overhanging branches, hydrants, light standards, etc.].</p> <p>1.3 The primary entrance has a power-operated door. [Automatic sliding doors are preferred. If a power door with a large paddle push plate is used, the plate should be located 1219 mm [4'0"] back from the door].</p> <p>1.4 It is preferred that entry doors provide a clear opening of 914 mm [3'0"] when the door is in a 90 degree open position.</p> <p>1.5 Doors with glazing should have a frame with a high colour-contrast.</p> <p>1.6 Lever handles on door hardware is required. On non-latching doors, a D-shaped pull handle is required. [e.g. Buildings in parks where it is not feasible to install an automatic door opener].</p>		

<p>1.7 For existing buildings, non-accessible entrances should have signage indicating where the accessible entrance is located.</p> <p>1.8 At vestibule entries [doors in series], provide 1500 mm [5'0"] between the end of the 90 degree open door and the next door in the vestibule.</p> <p>1.9 In case of emergency, provide a safe and accessible gathering place on the ground level outside of the building, where people with diverse abilities who have exited the building, can wait for further assistance.</p> <p>1.10 Provide benches with varying heights and armrests.</p>	       	
<p>2.0 Parking Areas</p>		
<p>2.1 Provide accessible parking stalls as per the requirements of the City of Richmond Zoning Bylaw 8500, Section 7 Parking and Loading</p> <p>2.2 Designated accessible parking stalls are located closest to an accessible building entrance in parking areas.</p> <p>2.3 A curb ramp to the sidewalk is located adjacent the accessible parking stall in a clearly demarcated aisle.</p> <p>2.4 An accessible parking symbol is painted on the designated parking space, and a vertical sign located 1829 mm [6'0"] above the ground level is situated at the centerline of the stall.</p> <p>2.5 Covered drop-off / pick-up zones are preferred, with appropriate overhead clearance for service vehicles.</p> <p>2.6 Provide a barrier-free non-obstructed path of travel from the parking area, on a sidewalk that is well lit and not prone to obstruction from the ends of parked vehicles.</p>	      	

3.0 Signage		Notes / Remarks
<p>3.1 All facilities and services for individuals with diverse abilities are identified with signage with appropriate symbols.</p> <p>3.2 Signage is large print, with high colour contrast and raised tactile lettering. Include braille in addition to print signage.</p> <p>3.3 Design general and way-finding signage that is consistent in all locations, and easily identifiable.</p> <p>3.4 Signage font is Sans Serif, e.g. Arial, and door signage should be located adjacent and not on the door.</p> <p>3.5 Incorporate virtual and/or audible accessibility technologies where possible.</p>		
4.0 Ramps, Stairs, Handrails, and Elevators		Notes / Remarks
<p>4.1 Slip-resistant tactile strips at stair and ramp landings, and at the beginning and end of the ramp, should have a high colour contrast.</p> <p>4.2 Avoid single isolated steps.</p> <p>4.3 The preferred maximum slope for a ramp is 1:16 if possible. [1:12 absolute maximum]. Avoid tight turns or switch backs for ramps.</p> <p>4.4 Provide a high contrasting colour on handrails. Terminate all handrails to the wall or to ground. A second lower height handrail on ramps is recommended, if climbability issues are not created.</p> <p>4.5 Provide yellow demarcation strips at the step edges and sides of escalator steps.</p> <p>4.6 Elevator doors should have a strong colour contrast from the surrounding walls.</p>		

<p>4.7 Clearly mark elevator locations and wayfinding at the main entrance of the building.</p> <p>4.8 The minimum size of the elevator cab is 1524 mm [5'0"] deep to permit the turning radius function for a wheelchair.</p> <p>4.9 Elevator buttons and emergency controls are located at an accessible height 1067 mm [3'6"] above finish floor, and incorporate large print tactile numbers and Braille mounted in raised fashion.</p> <p>4.10 Provide a visual indicator in the elevator signaling that "help is on the way".</p>		
<p>5.0 Washrooms</p>		<p>Notes / Remarks</p>
<p>5.1 For washrooms without entry doors, provide only one turn, to avoid feelings of disorientation.</p> <p>5.2 Provide appropriate signage outside washroom entrance and at cubicles,</p> <p>5.3 In addition to providing all accessible elements as required by code, increase the size of the accessible cubicle to 1829 mm [6'0"] wide x 2438 mm [8'0"] deep. Ensure the cubicle latch is of the large sliding variety (no thumb-turn).</p> <p>5.4 Provide a clear space of 1524 mm [5'0"] back from the lip of sink line to walls, or the face of toilet stalls opposite.</p> <p>5.5 Increase the dimensions of Universal Washrooms to incorporate a seating bench as well as diaper change table. Include an emergency call button in the room.</p>		

6.0 Other Interior Building Elements		Notes / Remarks
<p>6.1 Provide a public emergency phone at an accessible location.</p> <p>6.2 Provide a Built-In Typewriter [TTY] phone for users who are deaf or hard of hearing.</p> <p>6.3 Provide at least one accessible height drinking fountain.</p> <p>6.4 Include an accessible height portion for all counters where the public is served.</p> <p>6.5 Provide space for people using wheelchairs in all public seating areas. Include companion seating adjacent wheelchair seating areas.</p> <p>6.6 All glass doors and glass wall screens should have a contrasting colour strip at standing eye level and wheelchair seated eye level.</p> <p>6.7 All alarm systems should include a visual as well as an audible signal. [e.g. Flashing light]</p> <p>6.8 Zone intercoms to be more audibly legible. Install a read-o-graph to print out announcements that are made by loudspeaker.</p>	