



City of Richmond

Report to Committee

To: Parks, Recreation and Cultural Services
Committee

Date: June 24, 2013

From: Jane Fernyhough
Director, Arts, Culture and Heritage Services

File: 11-7000-09-20-133/Vol
01

Re: **Centro TerraWest Development Ltd. Donation of Public Art Project**

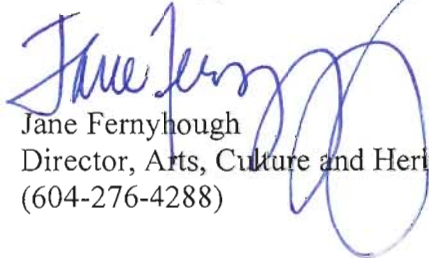

Staff Recommendation

That the artwork donation by Centro TerraWest Development Ltd. to the City of Richmond, as presented in the report dated June 24, 2013 from the Director, Arts, Culture and Heritage Services, be approved.

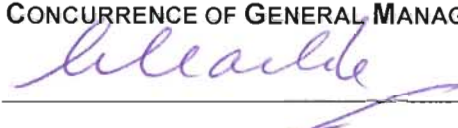

Jane Fernyhough
Director, Arts, Culture and Heritage Services
(604-276-4288)

Att. 3

REPORT CONCURRENCE			
ROUTED TO:	CONCURRENCE	CONCURRENCE OF GENERAL MANAGER	
Finance Division	<input checked="" type="checkbox"/>		
Parks Services	<input checked="" type="checkbox"/>		
Engineering	<input checked="" type="checkbox"/>		
Transportation	<input checked="" type="checkbox"/>		
Planning	<input checked="" type="checkbox"/>		
REVIEWED BY DIRECTORS	INITIALS: DW	REVIEWED BY CAO	INITIALS: 

Staff Report

Origin

As part of the Centro TerraWest development at 6011 No. 1 Road, the developer proposes to donate a public artwork to the City. This report presents for Council's consideration the proposed public artwork, artist and location.

This initiative is in line with Council Term Goal 9.1:

Build culturally rich public spaces across Richmond through a commitment to strong urban design, investment in public art and placemaking.

Finding of Facts

Richmond Public Art Program

The Richmond Public Art Program sets a framework for creating opportunities for people to experience art in everyday life, encouraging citizens to take pride in public cultural expression, and complement the character of Richmond's diverse neighbourhoods through the creation of distinctive public spaces. Donations of artwork to the City are an important part of Richmond's growing Public Art Collection.

Development Proposal

The Centro TerraWest development consists of a 4-storey mixed-use commercial/residential complex consisting of commercial space and 36 dwelling units. It is located at 6011 No. 1 Road, at the intersection with Westminster Highway, and across the street from the Terra Nova Shopping Centre. Council approved the development's rezoning application (RZ 2011 586705) on March 26, 2012 and development permit (DP 2011 588094) on November 13, 2012. As part of the rezoning and development permit, the developer agreed to integrate a public art project on the development's site or vicinity.

Terms of Reference

The Public Art Terms of Reference (**Attachment 1**) describe the art opportunity, site description, theme, budget, schedule, artist selection process, and submission criteria. The Terms of Reference were reviewed and endorsed by the Public Art Advisory Committee. An artist call for submissions was issued Fall 2012 with a deadline of October 25, 2012.

Public Art Selection Process

Donations of artwork are reviewed by an arm's length selection panel before being accepted into the City's Public Art Collection. A three member selection panel comprised of artists, community members and the Developer (Juliana Loh, Jasmine Reimer, and Kush Panatch) met on November 29, 2012. The panel reviewed fifteen artist submissions and recommended the proposal by Mark Ashby and Kim Cooper for the commission. The Richmond Public Art Advisory Committee has reviewed this proposal and endorses it as presented (**Attachment 2**).

Proposed Artwork

The proposed artwork, entitled *Float*, playfully intersperses six super-sized fishing floats, supported on welded metal chains, in the public realm adjacent to the sidewalk and between the

trees of the landscaped boulevard adjacent to the new commercial sidewalk on Westminster Highway.

Proposed Location

The proposed location of four of the six “floats” is on City owned sidewalk and boulevard space along Westminster Highway, immediately in front of the Centre TerraWest development. The remaining two “floats” are proposed to be located immediately back of the City sidewalk within the private property of the development (**Attachment 3**).

Planning, Parks, Transportation and Engineering staff have reviewed the proposed location in terms of urban design, boulevard maintenance, pedestrian safety, vehicular visibility, and have no concerns. The artwork will be designed so that it can easily be moved and returned to its location by City street crews if future utility or street work is required.

Staff Comments on Proposed Artwork Donation to the City

The Richmond Public Art Advisory Committee reviewed the proposal on June 18, 2013 and recommends that Council support this proposal of donated artwork by Centro TerraWest Development Ltd.

Cost of the artwork donation

The developer has contributed \$26,705 towards the selection, fabrication and installation of public art as a condition of the development approval process. Of this contribution, \$4,005 (15%) has been transferred to the Public Art Provision for City administration of the project. The artist contract is for \$20,000. The remaining funds, \$2,700, are being held for contingencies. A tax receipt for the donation would not be issued as the donation of the artwork is in exchange for development approvals.

Financial Impact

The artwork will require minimal periodic washing and maintenance, and security monitoring by the City at an approximate cost of \$300 per cleaning every one or two years. City funds would be allocated out of the Public Art Program’s annual operating budget.

Conclusion

The proposed artwork by Kim Cooper and Mark Ashby and donated by Centro TerraWest Development Ltd. represents a significant gift to the City of Richmond. It is a continuing show of support by developers for the importance of public art to neighbourhoods and the City.

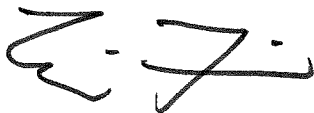

Eric Fiss
Public Art Planner
(604-247-4612)



City of
Richmond

Public Art Program



Centro TerraWest Public Art Project

Call to Artists – Request for Proposals Terms of Reference

The City of Richmond Public Art Program, on behalf of Centro TerraWest Development Ltd., seeks an artist or artist team to create a public artwork to accompany the construction of the mixed use project at 6011 & 6031 No. 1 Road, in the Thompson area of Richmond. This is an open call.

Budget: \$20,000 all inclusive
Installation: October, 2013
Deadline for Submissions: Thursday, October 25, 2012 @ 2:00 pm

For more information, contact the Public Art Program:

Phone: Eric Fiss at 604-247-4612

Email: publicart@richmond.ca

All images by Cotter Architects



Project Overview

Situated in the heart of the Thompson area of western Richmond (6011 and 6031 No. 1 Road, at No. 1 Road and the Westminister Highway) this development will anchor one of the neighbourhood's major intersections. TerraWest will be a mixed-use low-rise building that will include over 7700 square feet of commercial space at street level, and 36 residential units on the three upper floors. Designed in a contemporary West Coast style incorporating traditional materials, this development emphasizes integration into a liveable, pedestrian-friendly environment, with features such as rain gardens, seating, trees, and paving patterns.



Theme

TerraWest represents an exciting opportunity for art in a neighbourhood known for its access to schools, recreation, and parks, including nearby Terra Nova Rural Park and the dike trail. Artwork should not only serve as a place marker, but should enhance the streetscape experience for pedestrians. The selected artwork and theme will undergo development by the artist in discussion with the development project's design team.

Budget

The total budget established for this project is \$20,000. The budget includes (but is not limited to): artist fees, design, permitting as needed, engineering fees, fabrication, installation, photography and insurance. Travel to Richmond and/or accommodation is at the artist's expense.

For artist proposals that incorporate functional and/or planned features (including functional features such as balustrades, railings, concrete structures, brick fascia, etc.) the art budget is intended to "upgrade" the required element in order to make it an artistic feature.



Potential Artwork Sites

The best public exposure is to be found along the east (No. 1 Road) and north (Westminster Highway) sides of the building (above) and especially at or near the northeast corner of the building. Opportunities could potentially include placement among or enhancement of: green-space; public seating; bicycle stands; other ground level amenities; building features such as awning supports and work enhancing the exterior of the building itself.

Schedule (subject to change)

Submissions Close	2:00 p.m. on Thursday, October 25, 2012
Panel convened for recommendation	November 2012
Technical review and concept development	December 2012
Fabrication	begins January 2013
Installation	October 2013

Selection Panel & Process

A five-member selection panel will be appointed in accordance with the Public Art Program guidelines. The panel is likely to include the building architect and/or a representative of the developer. The panel may also include (but is not limited to) artists, design professionals, and community representation.

A five-person panel will review all submissions and select a proposal to recommend. The recommended artist and concept proposal will be reviewed by the Public Art Advisory Committee and presented to City Council for endorsement. The selected proposal will be subject to a Technical Review before implementation.

Selection Criteria

Submissions to the RFP will be reviewed and decisions made based on:

- Artist qualifications and proven capability to produce work of the highest quality;
- Artist's capacity to work in demanding environments with communities and other design professionals, where applicable;
- Appropriateness of the proposal to the project terms of reference and Public Art Program goals;
- Artistic merit of the proposal;
- Degree to which the proposal is site and community responsive, and technically feasible;
- Probability of successful completion;
- Environmental sustainability of the proposed artwork.
- Additional consideration may be given to proposals from artists who have not received commissions from the City of Richmond in the past three years.

Submission Requirements

All submissions should contain the following items and in the following order.

- Information Form (1 page)
 - A completed Information Form found on last page of this document.
- Letter of Interest (1 page maximum)
 - A typed letter of interest, including the artist's intent, rationale and a preliminary description of approach for this particular public art project. The letter should address the Selection Criteria (above) and include a statement about your artistic discipline and practice.
- Concept Sketch (1 page maximum)
 - Provide a concept sketch, maximum paper size 8.5 x 11 inches each. The final selected artist/artist team will be contracted to produce a final detailed design drawing or maquette under the terms of the artist agreement, prior to fabrication and installation of the artwork.
- Resume/Curriculum Vitae (2 pages maximum per artist)
 - Outline your experience as an artist, including any public art commissions. If you are submitting as a team, each member must provide a personal resume (each a maximum of 2 pages).
- Three References (1 page maximum)
 - Individuals who can speak to your art practice and interest and/or experience in public art projects. Please include: name, occupation, title, organization, address, primary phone number, email and a brief statement describing the nature of your working relationship to the reference listed.
 - Artist teams provide 3 references total. (on 1 page, maximum)
- Other Support Documentation (Optional) (2 pages maximum)
 - This documentation may include (please properly cite all sources):
 - Recent reviews and news clippings
 - Excerpts from programs, catalogues and other publications that include examples of your work
- Annotated List of Images of Past Work (1 page maximum)
 - Provide the following information for all images: title of work, medium, approx. dimensions, location and date and the image file name. Artists are also encouraged to include a brief description.
- Images of Past Work (10 images maximum)
 - One image per page (full size).
 - Do not place any text on or around the image

Submission Guidelines

This RFP accepts paper submissions via mail or delivered in person. Electronic submissions are accepted and encouraged. Submissions must be complete and strictly adhere to these guidelines and Submission Requirements (above) or risk not being considered. Faxed submissions will not be accepted.

- All submissions (electronic and print) must be formatted to 8.5 x 11 inch pages. Do not send any models or maquettes.
- The Artist's (or Team's) name should appear in the right header of every page.
- Do not submit any original materials or files. Submissions will not be returned.
- Do not bind, staple or use plastic cover sheets.

In addition, electronic submissions:

- Must be submitted in MS Word or PDF format. Do not submit materials that require plug-ins, extensions or other executables that need to be downloaded or installed. Do not compress (zip) files
- Must be self-contained. Do not imbed links to other websites or on-line documentation or media.
- Must be contained in one single document. Do not submit multiple electronic documents.
- Must be 10MB or smaller (if emailed). Submission over 10MB must be sent via PC-compatible CD.

Submitting as a Team

The team should designate one representative to complete the entry form. Team submissions must adhere to the specific submission guidelines with the following exceptions:

- Each team member must submit an individual Resume/CV (See Submission Requirements)
- All Team Members must list their full names on the space provided on the Information Form

Deadline for Submissions

Submissions must be received by Thursday, October 25, 2012 @ 2:00 pm. This is not a postmark date. Extensions to this deadline will not be granted under any circumstances. Submissions received after the deadline and those that are found to be incomplete will not be reviewed.

It is the applicant's responsibility to ensure the submission package reaches the City of Richmond by the deadline.

Email, mail or deliver submissions to:

Richmond Public Art Program
City of Richmond
6911 No.3 Road
Richmond, BC V6Y 2C1
604-204-8671
publicart@richmond.ca

For questions and information, contact:

Eric Fiss, MAIBC, MCIP, LEED AP
Public Art Planner
City of Richmond
604-247-4612
efiss@richmond.ca

Additional Information

Please be advised that the City and the selection panel are not obliged to accept any of the submissions, and may reject all submissions. The City reserves the right to reissue the RFP as required.

All information provided under the submission shall be considered confidential and shall only be disseminated to City staff and partners for the purposes of the selection process. All submissions to this RFP become the property of the City and will be held in confidence as required by law. The artist shall retain copyright in the concept proposal.

While every precaution will be taken to prevent the loss or damage of submissions, the City and its agents shall not be liable for any loss or damage, however caused.

For more information on the Public Art Program please visit www.richmond.ca/publicart.

CENTRO TERRAWEST Submission Deadline: Thursday, October 25, 2012 @ 2:00 pm

Attach one (1) copy of this form as the first page of the submission.

PLEASE NOTE: You can type your responses into this PDF document.

Name: _____

Team Name (if applicable): _____

Address: _____

City/Postal Code _____

Primary Phone: _____ Secondary Phone: _____

Email _____ Website: _____

(one website or blog only)

Submission Checklist

Please provide these items *in the following order* (as outlined in Submission Requirements):

- Information Form (*this page*)
- Letter of interest (*maximum 1 page*)
- Concept Sketch (*maximum 1 page*)
- Resume/Curriculum vitae (*maximum 2 pages per team member, if applicable*)
- Three References (*name, title, contact information: maximum 1 page*)
- Other Support Documentation (*Optional*) (*maximum 2 pages*)
- Annotated List of Past Work (*maximum 1 page*)
- Ten Images of Past Work (*maximum 10 pages: do not include multiple images on one page; inserting image files as pages in pdf submission documents is recommended; landscape orientation is recommended.*)

Incomplete or faxed submissions will not be accepted. Emailed submissions over 10MB will not be accepted. Information beyond what is listed in the checklist will not be reviewed.

List Team Member Names Here (Team Lead complete above portion):

Please let us know how you found out about this opportunity:

Would you like to receive direct emails from the Richmond Public Art Program? _____

Signature: _____ Date: _____

Deliver to: City of Richmond, Public Art
6911 No. 3 Rd. Richmond, BC, V6Y 2C1

Or by email to:
publicart@richmond.ca

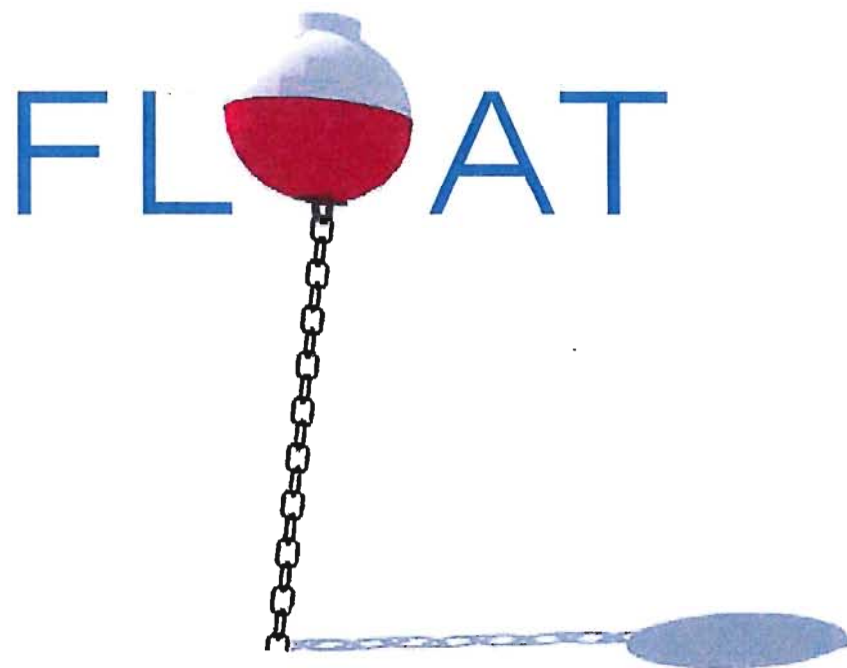

DESIGN DEVELOPMENT
13.05 24

Kim Cooper, *M.Arch, Dip. Studio Art*
Mark Ashby, *Architect, AIBC*

Kim Cooper, **M.Arch, Dip. Studio Art**
Mark Ashby, **Architect, AIBC**

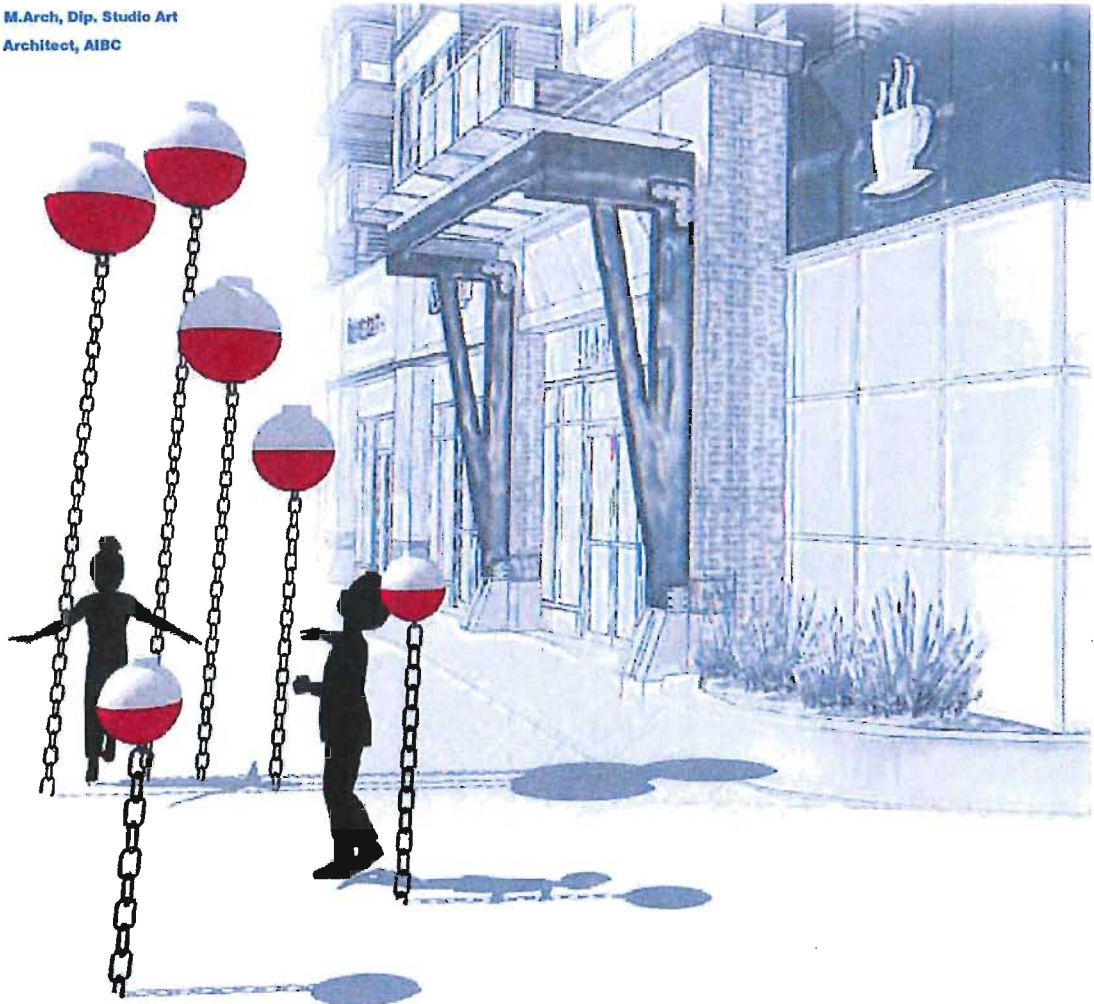

original concept

A City grows in population and cultural sophistication in the inexorable context of change. Embraced by the flow, we are unconscious of the dynamics of our place until we encounter something fixed against which to measure our movement.



float is a sculptural arrangement of hollow balls supported on solid posts of welded, heavy-gauge chain. Accustomed as we are to the use of chain in the maritime environment, the piece will create the illusion of buoyancy causing the balls to appear to float.



Located on the landscaped boulevard, **float** will exist in dialog with the street-trees and lamp standards. Constructed from durable materials, **float** will provide infrastructure for ad-hoc children's games, a leaning post or a secure bicycle rack for the adjacent businesses.

The piece is deliberately open-ended, blending benign and sinister metaphors, celestial and microscopic scales, harsh environmental predictions and nostalgic childhood past-times.

Kim Cooper, M.Arch, Dip. Studio Art
Mark Ashby, Architect, AIBC

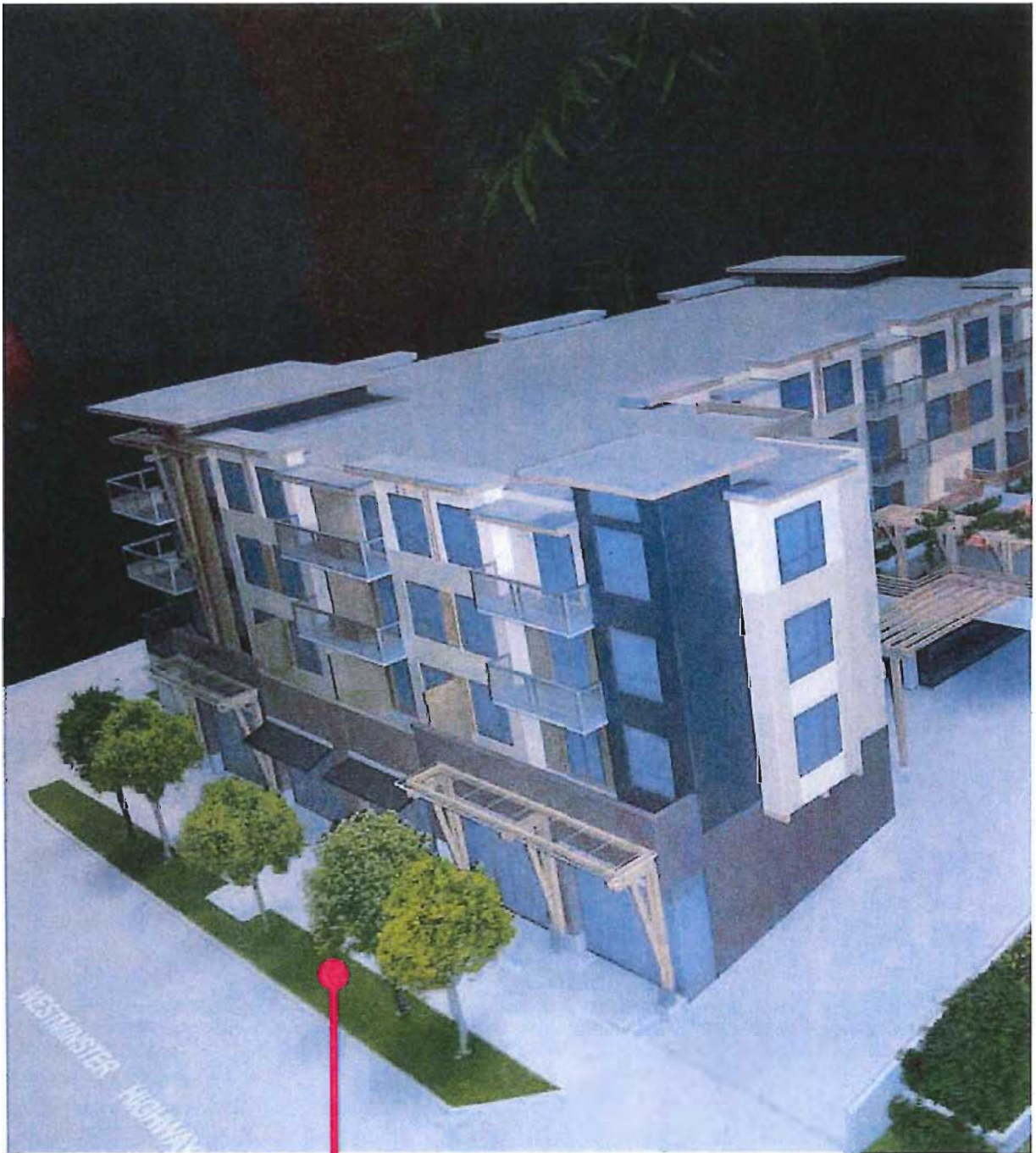

Proposed location of artwork

Kim Cooper, **M.Arch, Dip. Studio Art**
Mark Ashby, **Architect, AIBC**



Aerial view looking west



Aerial view looking southwest

Kim Cooper, *M.Arch, Dip. Studio Art*
Mark Ashby, *Architect, AIBC*



North elevation 1/8" = 1'-0"

Kim Cooper, M.Arch, Dip. Studio Art
Mark Ashby, Architect, AIBC

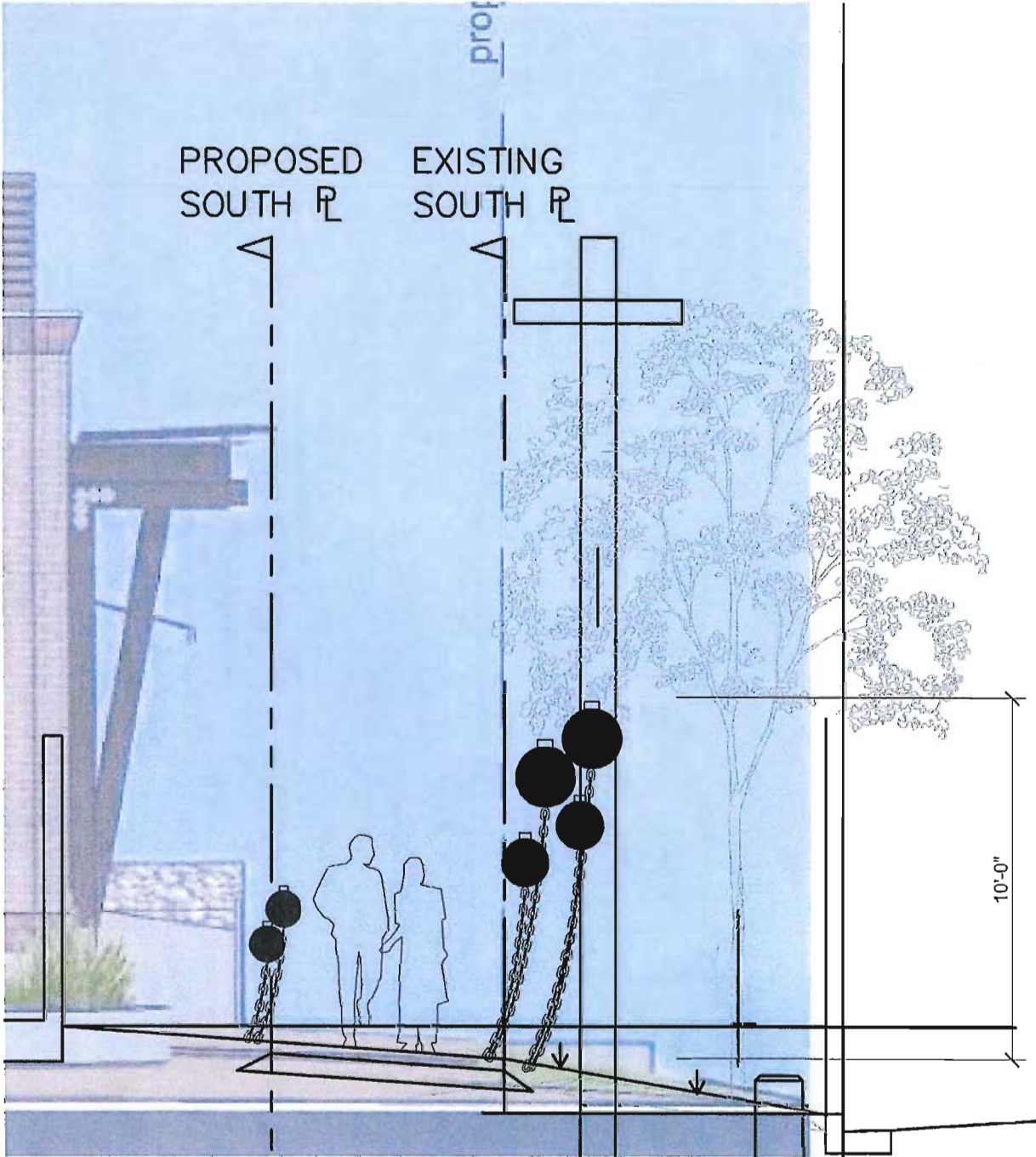

West elevation 1/4" = 1'-0"



Kim Cooper, M.Arch, Dip. Studio Art
 Mark Ashby, Architect, AIBC

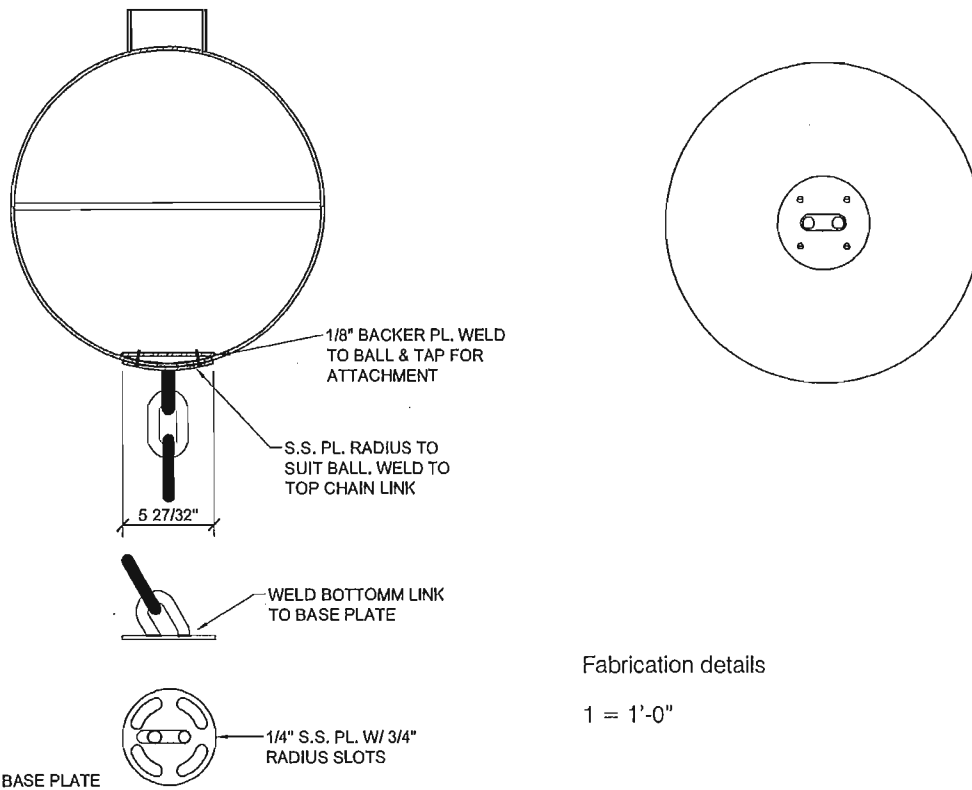
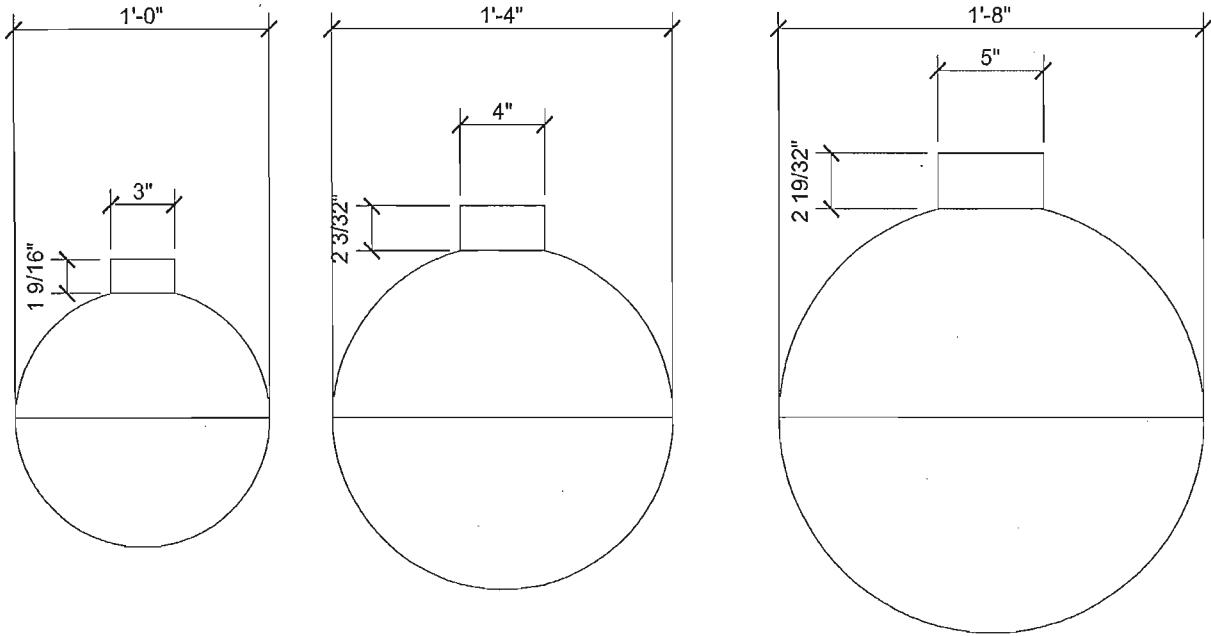

Fabrication details

1 = 1'-0"

Kim Cooper, *M.Arch, Dip. Studio Art*
Mark Ashby, *Architect, AIBC*

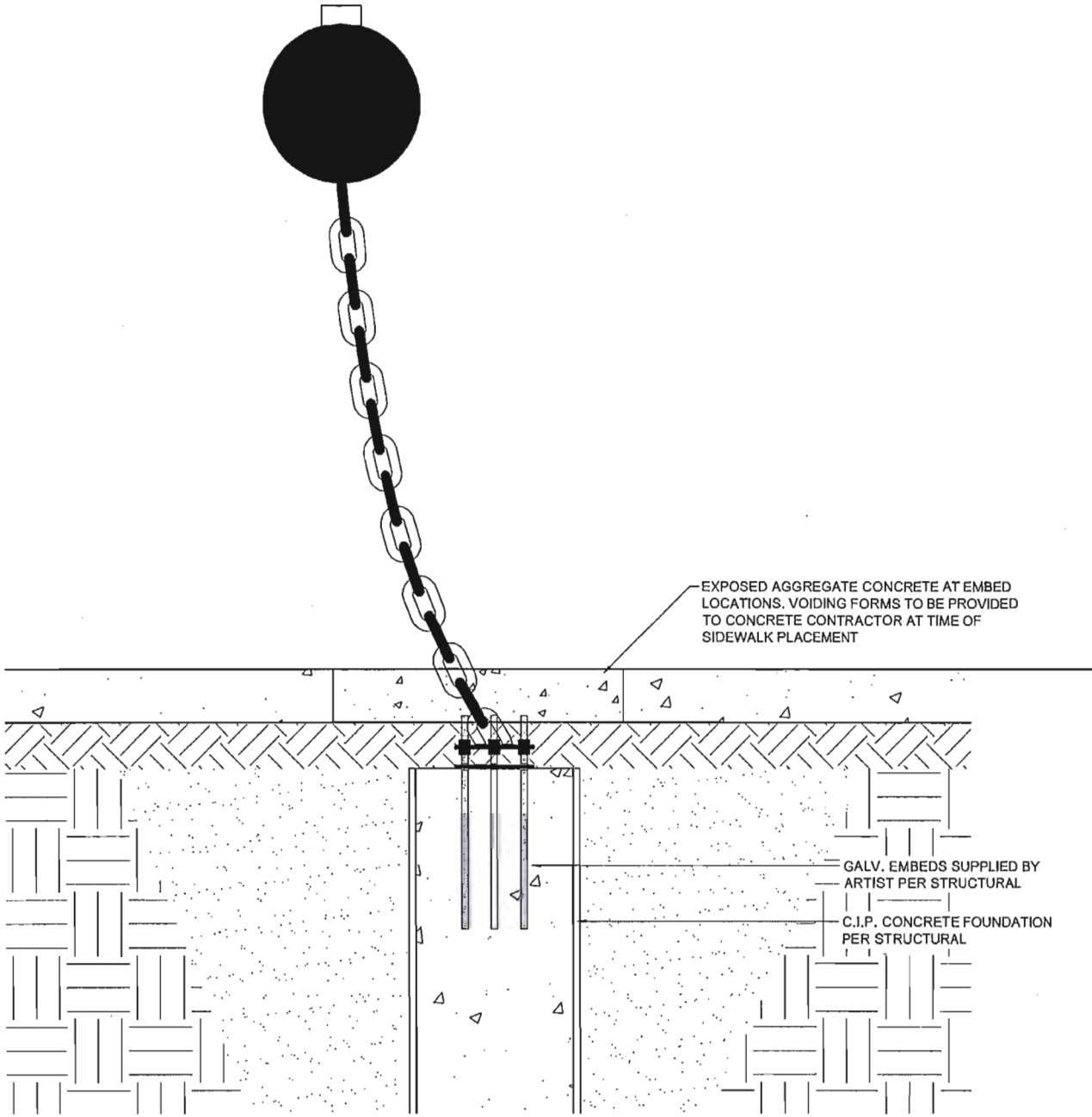

Foundation detail

1" = 1'-0"



Kim Cooper, M.Arch, Dip. Studio Art
Mark Ashby, Architect, AIBC

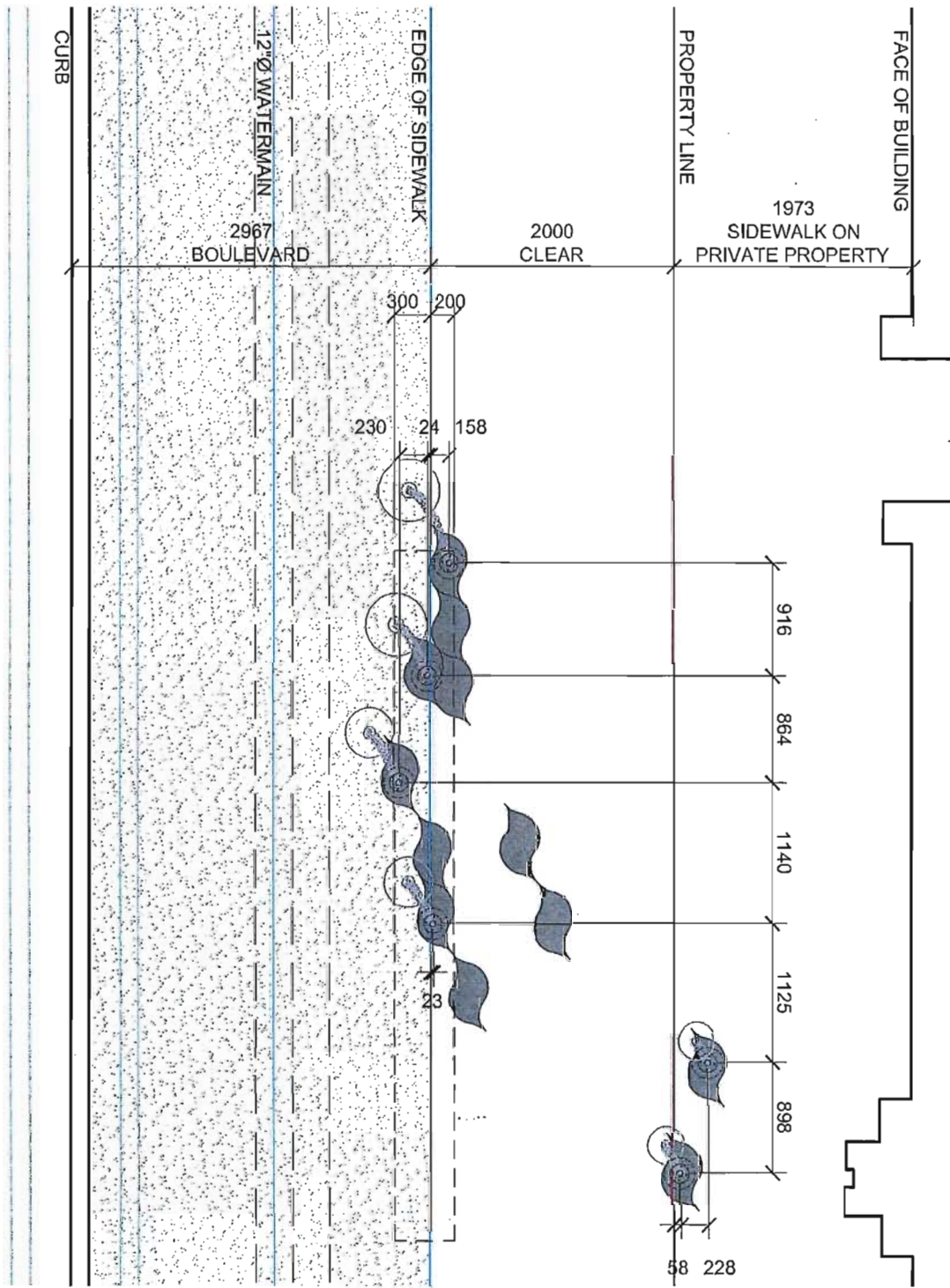

Detail plan

1/4" = 1'-0"