



# City of Richmond

## Report to Committee Planning and Development Division

**To:** Planning Committee  
**From:** Wayne Craig  
Director, Development

**Date:** October 3, 2016  
**File:** RZ 16-737446

**Re:** Application by Anuvir Dehal for Rezoning at 8140 Heather Street from Single Detached (RS1/E) to Single Detached (RS2/A)

### Staff Recommendation

That Richmond Zoning Bylaw 8500, Amendment Bylaw 9623, for the rezoning of 8140 Heather Street from "Single Detached (RS1/E)" to "Single Detached (RS2/A)", be introduced and given first reading.

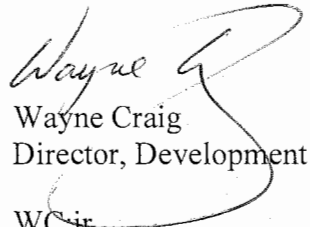
  
Wayne Craig  
Director, Development  
WC:jr  
Att. 7

REPORT CONCURRENCE		
ROUTED TO:	CONCURRENCE	CONCURRENCE OF GENERAL MANAGER
Affordable Housing	<input checked="" type="checkbox"/>	

## Staff Report

### Origin

Anuvir Dehal has applied to the City of Richmond for permission to rezone 8140 Heather Street from the "Single Detached (RS1/E)" zone to the "Single Detached (RS2/A)" zone, to permit the property to be subdivided into two (2) single-family lots with vehicle access from Heather Street (Attachment 1). The proposed subdivision plan is shown in Attachment 2. There is an existing home on the property, which would be demolished.

### Findings of Fact

A Development Application Data Sheet providing details about the development proposal is provided in Attachment 3.

### Surrounding Development

Development immediately surrounding the subject site is as follows:

- To the North, one (1) home on a lot zoned "Single Detached (RS2/A)," fronting Heather Place.
- To the South, two (2) homes on lots zoned "Single Detached (RS1/E)," one (1) fronting Heather Place and one (1) fronting Dixon Avenue.
- To the East, a townhouse complex on a lot zoned "Low Density Townhouses (RTL1)," with vehicle access from Ash Street and Blundell Road.
- To the West, across Heather Street, a commercial centre on a lot zoned "Community Commercial (CC)."

### Related Policies & Studies

#### Official Community Plan/Broadmoor Area Plan

The subject property is located in the Broadmoor planning area. The Official Community Plan (OCP) designation for the subject property is "Neighbourhood Residential" (Attachment 4). The proposed rezoning is consistent with this designation.

The subject property is located within the area governed by the Ash Street Sub-Area Plan contained in the OCP. The land use designation for the subject property is "Low Density Residential" (Attachment 5). The Ash Street Sub-Area Plan permits the development of lands outside of designated infill sites shown on the Land Use Map to be governed by the City's normal development application process. The City has considered numerous rezoning applications in the area, which have resulted in lots between 9 and 10 metres wide. The proposed rezoning is consistent with the land use designation and policies contained in the Ash Street Sub-Area Plan.

## **Floodplain Management Implementation Strategy**

The proposed redevelopment must meet the requirements of the Richmond Flood Plain Designation and Protection Bylaw 8204. Registration of a flood indemnity covenant on Title is required prior to final adoption of the rezoning bylaw.

## **Public Consultation**

A rezoning sign has been installed on the subject property. Staff have not received any comments from the public about the rezoning application in response to the placement of the rezoning sign on the property.

Should the Planning Committee endorse this application and Council grant 1<sup>st</sup> reading to the rezoning bylaw, the bylaw will be forwarded to a Public Hearing, where any area resident or interested party will have an opportunity to comment.

Public notification for the Public Hearing will be provided as per the Local Government Act.

## **Analysis**

### **Existing Legal Encumbrances**

There is an existing 3.0 m statutory right-of-way (SRW) across the entire rear (east) property line for the sanitary sewer, which will not be impacted by this development proposal. The applicant is aware that encroachment into the SRW is not permitted.

### **Transportation and Site Access**

Vehicle access is proposed to be provided from Heather Street via separate driveway crossings to each new lot.

Prior to the issuance of a Building Permit, the applicant is required to submit a Construction Parking and Traffic Management Plan to the City's Transportation Department for review.

### **Tree Retention and Replacement**

The applicant has submitted a Certified Arborist's Report; which identifies on-site and off-site tree species, assesses tree structure and condition, and provides recommendations on tree retention and removal relative to the proposed development. The Report assesses five (5) bylaw-sized trees on the subject property and one (1) tree on City property.

The City's Tree Preservation Coordinator has reviewed the Arborist's Report and has the following comments:

- Two (2) bylaw-sized trees within a Western red cedar hedgerow (Tag # 151) on the subject property have been historically topped and cannot be retained as individual trees due to their suppressed canopies. Remove and replace.

- Four (4) bylaw-sized trees within a Western red cedar hedgerow (Tag # 150) on the subject property have been historically topped and cannot be retained as individual trees due to their suppressed canopies. Remove and replace.
- One (1) untagged Japanese maple tree located on the development site is in direct conflict with the building envelope and cannot be retained. Remove and replace.
- One (1) Deodar cedar tree (Tag # 149) located on City property is in poor condition and recommended for removal. Compensation required at a 2:1 ratio.
- Replacement trees should be specified at 2:1 ratio as per the OCP.

*Tree Replacement*

The applicant wishes to remove seven (7) on-site trees (Tag # 150, 151) (Attachment 6). The 2:1 replacement ratio would require a total of fourteen (14) replacement trees. The applicant has agreed to plant three (3) trees on each lot proposed; for a total of six (6) trees. The required replacement trees are to be of the following minimum sizes, based on the size of the trees being removed as per Tree Protection Bylaw No. 8057.

No. of Replacement Trees	Minimum Caliper of Deciduous Replacement Tree	Minimum Height of Coniferous Replacement Tree
4	6 cm	3.5 m
2	10 cm	5.5 m

To satisfy the 2:1 replacement ratio established in the OCP, the applicant will contribute \$4,000 to the City’s Tree Compensation Fund in lieu of the remaining eight (8) trees that cannot be accommodated on the subject property after redevelopment.

The applicant wishes to remove one (1) City-owned tree (Tag # 149) and a hedge in the Heather Street right-of-way. The applicant has agreed to provide compensation of \$1,300 as requested by the Parks Department for the City to plant two (2) trees at or near the subject property.

**Affordable Housing Strategy**

The City’s Affordable Housing Strategy requires a secondary suite or coach house on 100% of new lots created through single-family rezoning and subdivision applications; a secondary suite or coach house on 50% of new lots created and a cash-in-lieu contribution to the City’s Affordable Housing Reserve Fund of \$2.00/ft<sup>2</sup> of the total buildable area of the remaining lots; or a cash-in-lieu contribution of \$2.00/ft<sup>2</sup> of the total buildable area of all lots where a secondary suite cannot be accommodated in the development.

The applicant proposes to contribute \$9,803.76 toward the City’s Affordable Housing Reserve Fund. This is equivalent to \$2.00/ft<sup>2</sup> of the total buildable area of each lot to be created, and is consistent with the Affordable Housing Policy.

**Site Servicing and Frontage Improvements**

At a future development stage, the applicant must complete the required servicing works as described in Attachment 7, through either a Servicing Agreement or a work order.

At Subdivision stage, the applicant is required to pay, in keeping with the Subdivision and Development Bylaw No. 8751, a \$22,679.60 cash-in-lieu contribution for the design and construction of frontage upgrades as set out in Attachment 7.

### **Financial Impact or Economic Impact**

This rezoning application results in an insignificant Operational Budget Impact (OBI) for off-site City infrastructure (such as roadworks, waterworks, storm sewers, sanitary sewers, street lights, street trees and traffic signals).

### **Conclusion**

The purpose of this application is to rezone 8140 Heather Street from the "Single Detached (RS1/E)" zone to the "Single Detached (RS2/A)" zone, to permit the property to be subdivided to create two (2) lots.

This rezoning application complies with the land use designations and applicable policies for the subject site contained within the OCP and the Richmond Zoning Bylaw 8500.

The list of rezoning considerations is included in Attachment 7, which has been agreed to by the applicant (signed concurrence on file).

It is recommended that Richmond Zoning Bylaw 8500, Amendment Bylaw 9623 be introduced and given first reading.



Jordan Rockerbie  
Planning Technician

JR:rg

- Attachment 1: Location Map and Aerial Photo
- Attachment 2: Proposed Subdivision Plan
- Attachment 3: Development Application Data Sheet
- Attachment 4: Broadmoor Area Plan Land Use Map
- Attachment 5: Ash Street Sub-Area Plan Land Use Map
- Attachment 6: Tree Management Plan
- Attachment 7: Rezoning Considerations



# City of Richmond

ATTACHMENT 1

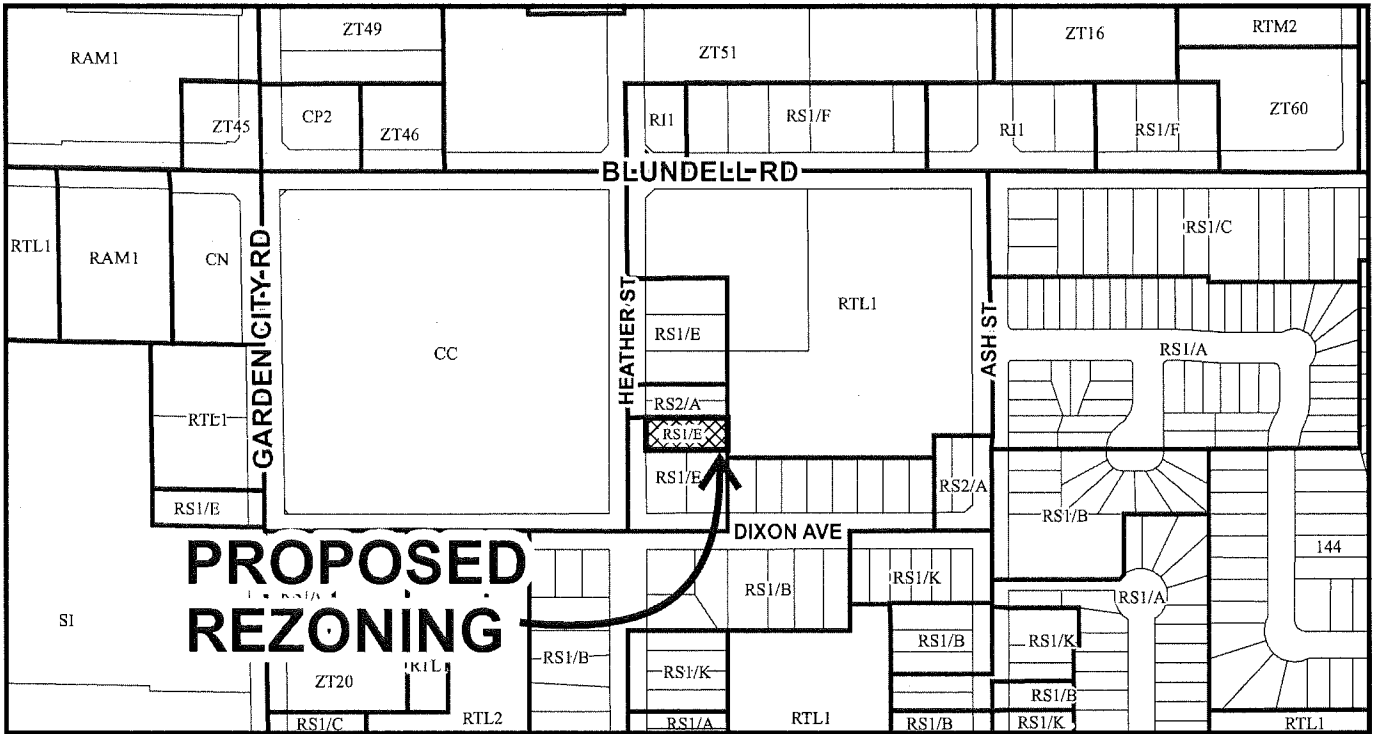

## PROPOSED REZONING

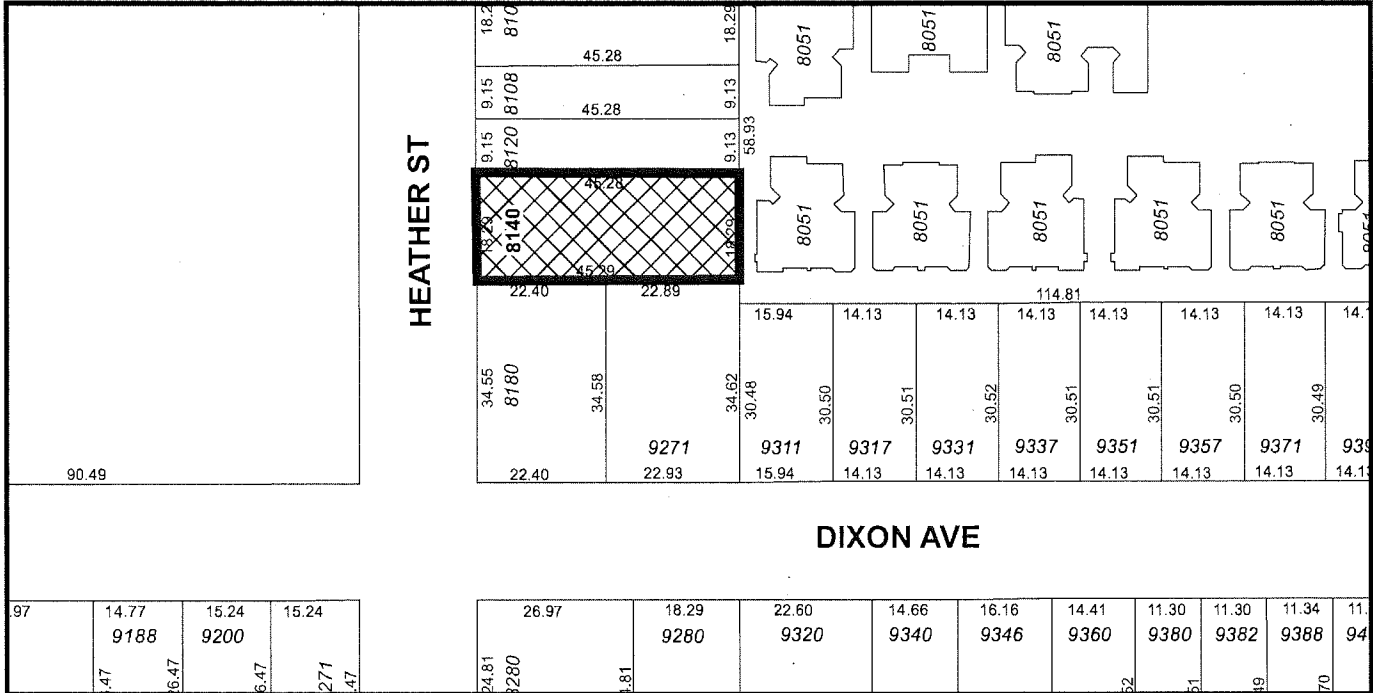

# RZ 16-737446

Original Date: 08/04/16

Revision Date:

Note: Dimensions are in METRES





City of  
Richmond



RZ 16-737446

Original Date: 08/04/16

Revision Date:

Note: Dimensions are in METRES

**TOPOGRAPHIC SURVEY AND PROPOSED SUBDIVISION OF LOT 556**  
**SECTION 22 BLOCK 4 NORTH RANGE 6 WEST**  
**NEW WESTMINSTER DISTRICT PLAN 60575**

#8140 HEATHER STREET,  
 RICHMOND, B.C.  
 P.I.D. 002-551-381

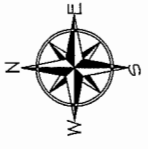

SCALE: 1:200  
 0 5 10 15  
 ALL DISTANCES ARE IN METRES AND DECIMALS  
 THEREOF UNLESS OTHERWISE INDICATED

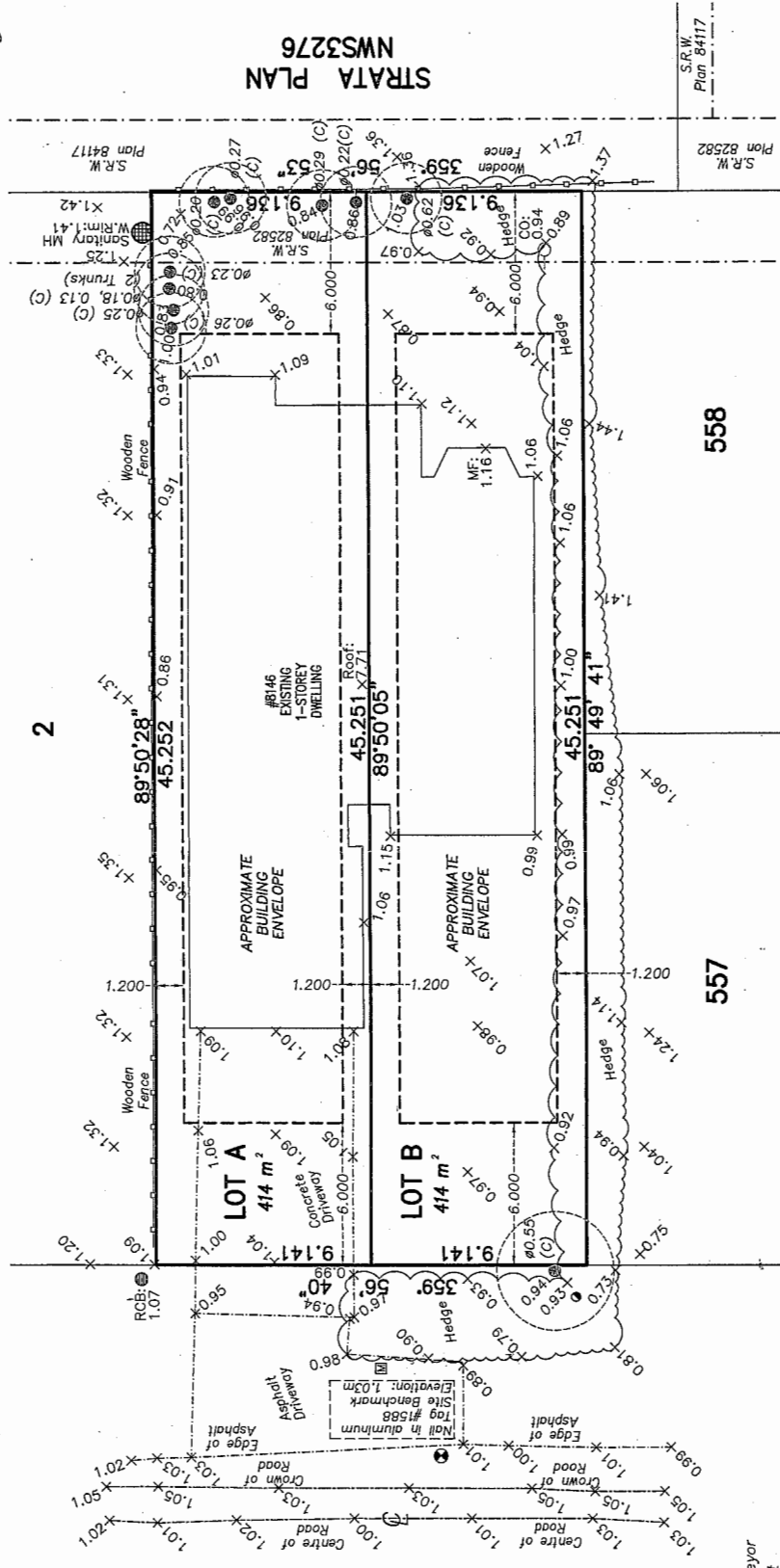

**NOTE:**  
 Elevations shown are based on  
 City of Richmond HPN  
 Benchmark network.  
 Benchmark: HPN #234  
 Control Monument 77H4891  
 Elevation: 1.125m  
 Benchmark: HPN #235  
 Control Monument 77H4885  
 Elevation: 1.103m

**LEGEND:**  
 (C) denotes conifer  
 ● denotes round catch basin  
 ○ denotes water meter  
 ○ denotes manhole  
 ○ denotes cleanout  
 ○ denotes power post  
 MF denotes main floor

copyright  
 J. C. Tam and Associates  
 Canada and B.C. Land Surveyor  
 115 - 8633 Odlin Crescent  
 Richmond, B.C. V6X 3Z7  
 Telephone: 214-8928  
 Fax: 214-8929  
 E-mail: office@jctam.com  
 Website: www.jctam.com  
 Job No. 6341  
 FB-299 P7-10  
 Drawn By: IO

**DWG No. 6341-Topo**

**CERTIFIED CORRECT:**  
 LOT DIMENSION ACCORDING TO  
 FIELD SURVEY.  
  
 JOHNSON C. TAM, B.C.L.S.  
**JANUARY 13th, 2015.**





**RZ 16-737446**

**Attachment 3**

Address: 8140 Heather Street

Applicant: Anuvir Dehal

Planning Area(s): Broadmoor – Ash Street Sub-Area

	Existing	Proposed
<b>Owner:</b>	Narinderjit Singh Dehal Paramjit Kaur Dehal Anuvir Singh Dehal	To be determined
<b>Site Size (m<sup>2</sup>):</b>	828 m <sup>2</sup>	Lot A: 414 m <sup>2</sup> Lot B: 414 m <sup>2</sup>
<b>Land Uses:</b>	One (1) single-family home	Two (2) single-family homes
<b>OCP Designation:</b>	Neighbourhood Residential	No change
<b>Area Plan Designation:</b>	Low density residential	No change
<b>Zoning:</b>	Single Detached (RS1/E)	Single Detached (RS2/A)

On Future Subdivided Lots	Bylaw Requirement	Proposed	Variance
Floor Area Ratio:	Max. 0.55 for lot area up to 464.5 m <sup>2</sup> plus 0.3 for area in excess of 464.5 m <sup>2</sup>	Max. 0.55 for lot area up to 464.5 m <sup>2</sup> plus 0.3 for area in excess of 464.5 m <sup>2</sup>	None permitted
Buildable Floor Area (m <sup>2</sup> ):*	Lot A: Max. 227.7 m <sup>2</sup> (2,450.94 ft <sup>2</sup> ) Lot B: Max. 227.7 m <sup>2</sup> (2,450.94 ft <sup>2</sup> )	Lot A: Max. 227.7 m <sup>2</sup> (2,450.94 ft <sup>2</sup> ) Lot B: Max. 227.7 m <sup>2</sup> (2,450.94 ft <sup>2</sup> )	None permitted
Lot Coverage (% of lot area)	Building: Max. 45% Non-porous Surfaces: Max. 70%	Building: Max. 45% Non-porous Surfaces: Max. 70%	None
Lot Size:	Min. 270.0 m <sup>2</sup>	414.0 m <sup>2</sup>	None
Lot Dimensions (m):	Width: Min. 9.0 m Depth: Min. 24.0 m	Width: 9.14 m Depth: 45.25 m	None
Setbacks (m):	Front: Min. 6 m Rear: Min. 6 m Side: Min. 1.2 m	Front: Min. 6 m Rear: Min. 6 m Side: Min. 1.2 m	None
Height (m):	Max. 9.0 m	Max. 9.0 m	None

Other: Tree replacement compensation required for loss of significant trees.

\* Preliminary estimate; not inclusive of garage; exact building size to be determined through zoning bylaw compliance review at Building Permit stage.



## 6. Broadmoor

SUBJECT  
PROPERTY

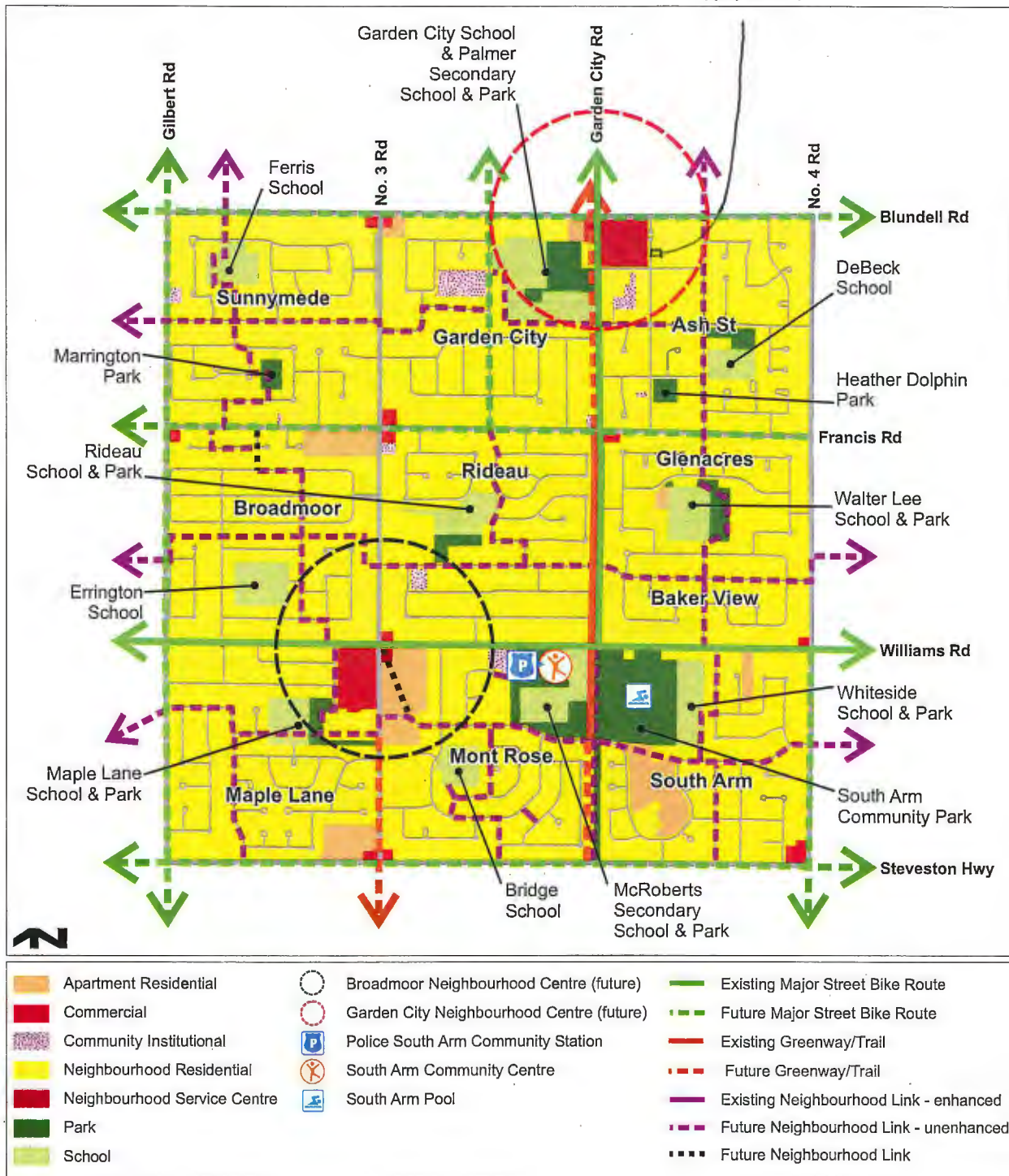



City of Richmond

Land Use Map *Bylaw 9489  
2016/07/18*

SUBJECT  
PROPERTY

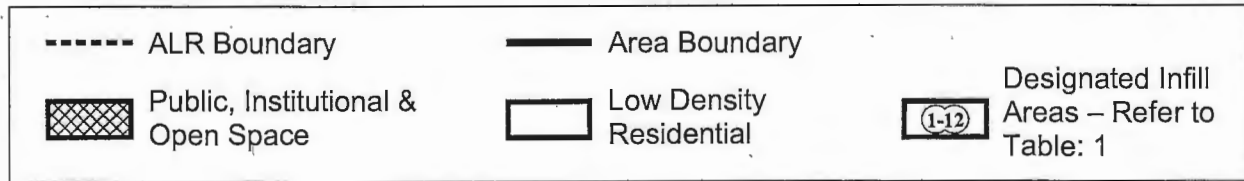
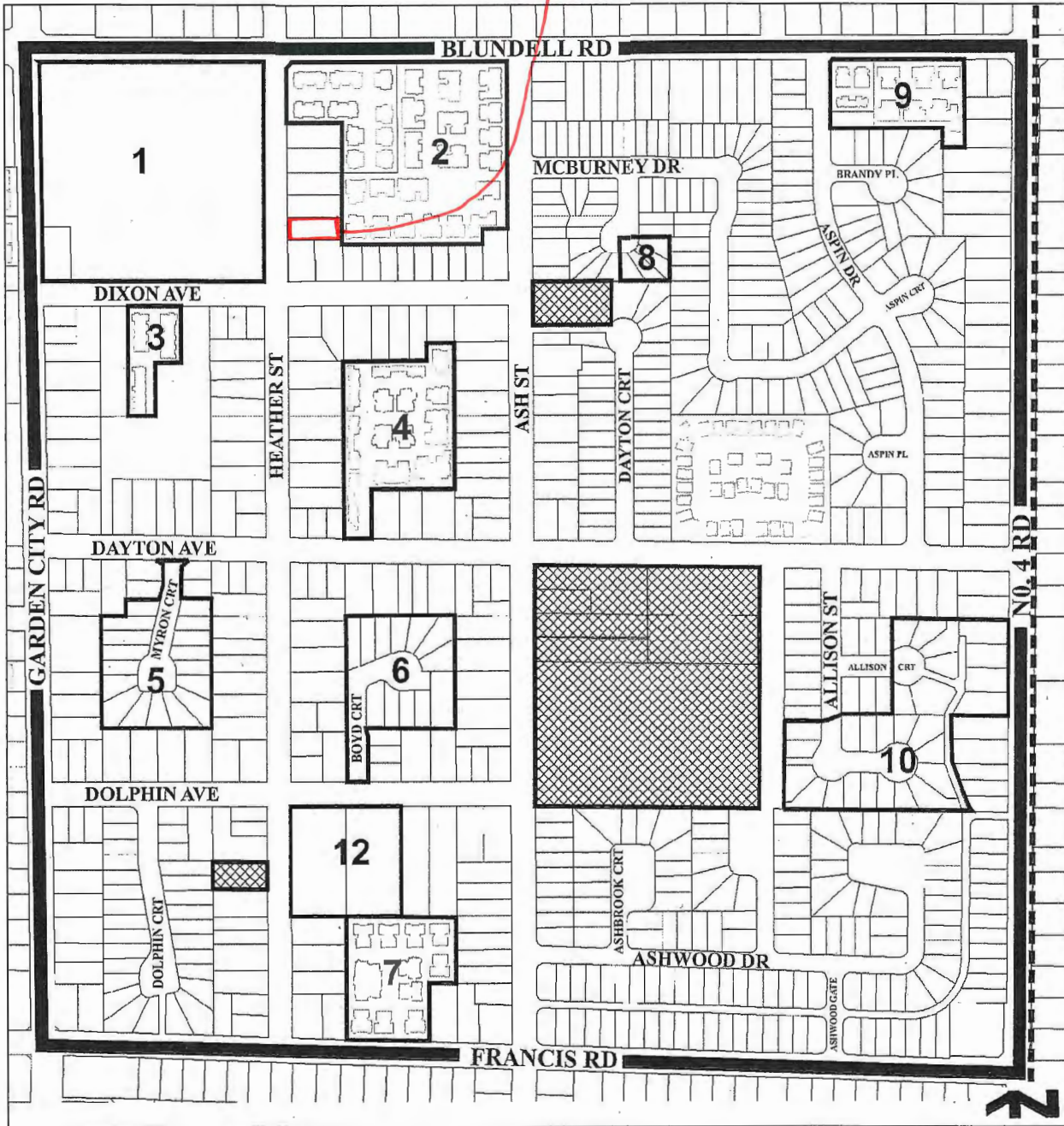

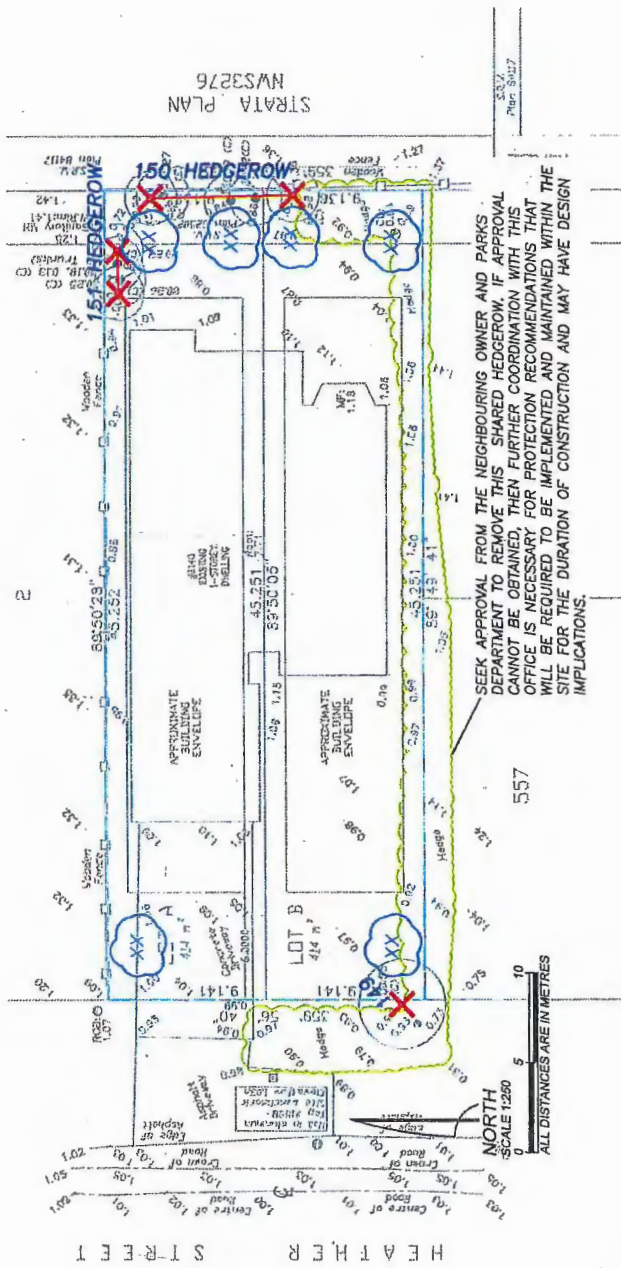

STRATA PLAN  
NWS3276

SEEK APPROVAL FROM THE NEIGHBOURING OWNER AND PARKS DEPARTMENT TO REMOVE THIS SHARED HEDGEROW. IF APPROVAL CANNOT BE OBTAINED THEN FURTHER COORDINATION WITH THIS OFFICE IS NECESSARY FOR PROTECTION RECOMMENDATIONS THAT WILL BE REQUIRED TO BE IMPLEMENTED AND MAINTAINED WITHIN THE SITE FOR THE DURATION OF CONSTRUCTION AND MAY HAVE DESIGN IMPLICATIONS.

**LEGEND:**

- denotes TAG NUMBER or ID REFERENCE.
- denotes ALDER or COTONWOOD TREE (unlogged by law size).
- denotes DRIPLINE (spread of the branches and foliage) of the tree.
- denotes RETENTION tree [proposed].
- denotes REMOVAL tree [proposed].
- denotes HIGH RISK REMOVAL tree [proposed].
- denotes OFF-SITE tree (to be protected and/or owner contacted as noted).
- denotes NON-BY-LAW underside tree (as measured by project arborist).
- denotes SITE or STUDY AREA BOUNDARY.
- denotes TREE PROTECTION ZONE (TPZ) setback alignment as specified by project arborist.
- denotes REPLACEMENT TREE proposed (conceptual location - see plant list for details).

**PLAN NOTES:**  
This plan is an advisory drawing. It is not a contract. The client is responsible for ensuring that the information provided is accurate and up-to-date. The client is responsible for ensuring that the information provided is accurate and up-to-date. The client is responsible for ensuring that the information provided is accurate and up-to-date.

**SEE SHEET 1 FOR TREE DATA AND SPECIFICATIONS**

REV #	DATE	INITIAL SUBMISSION	COMMENTS
0	MAR 25, 2018		

<b>TREE MANAGEMENT DRAWING</b>	
PROJECT:	PROPOSED 2-LOT SUBDIVISION
ADDRESS:	8140 HEATHER STREET, RICHMOND
CLIENT:	ANUVIR DEHAL
ACL FILE:	16142

ARBORTECH CONSULTING

SUITE 145 - 12051 HORSESHOE WAY, RICHMOND, BC V7A 4V4 P. 604 276 3464



Address: 8140 Heather Street

File No.: RZ 16-737446

**Prior to final adoption of Richmond Zoning Bylaw 8500, Amendment Bylaw 9623, the applicant is required to complete the following:**

1. Submission of a Landscape Security in the amount of \$3,000 (\$500/tree) to ensure that a total of three (3) replacement trees are planted and maintained on each lot proposed (for a total of six (6) trees). Replacement trees should result in a mix of coniferous and deciduous trees on each lot, and must be of the following minimum sizes:

No. of Replacement Trees	Minimum Caliper of Deciduous Replacement Tree	Minimum Height of Coniferous Replacement Tree
Four (4)	6 cm	3.5 m
Two (2)	10 cm	5.5 m

2. City acceptance of the developer's offer to voluntarily contribute \$4,000 to the City's Tree Compensation Fund for the planting of replacement trees within the City.
3. City acceptance of the Developer's \$1,300 payment as compensation for the one (1) City-owned tree to be removed, so that the City may plant two (2) trees at or near the development site.
4. Registration of a flood indemnity covenant on title.
5. The City's acceptance of the applicant's voluntary contribution of \$2.00 per buildable square foot of the single-family developments (i.e. \$9,803.76) to the City's Affordable Housing Reserve Fund.

**Note:** Should the applicant change their mind about the Affordable Housing option selected prior to final adoption of the Rezoning Bylaw, the City will accept a proposal to build a secondary suite on each of the two (2) future lots at the subject site; or on one (1) of the two (2) future lots with a \$4,901.88 contribution to the City's Affordable Housing Reserve Fund. To ensure that a secondary suite is built to the satisfaction of the City in accordance with the Affordable Housing Strategy, the applicant is required to enter into a legal agreement registered on Title as a condition of rezoning, stating that no final Building Permit inspection will be granted until a secondary suite is constructed to the satisfaction of the City, in accordance with the BC Building Code and the City's Zoning Bylaw.

**Prior to Building Permit Issuance, the applicant must complete the following requirements:**

1. Submission of a Construction Parking and Traffic Management Plan to the Transportation Department. Management Plan shall include location for parking for services, deliveries, workers, loading, application for any lane closures, and proper construction traffic controls as per Traffic Control Manual for works on Roadways (by Ministry of Transportation) and MMCD Traffic Regulation Section 01570.
2. Obtain a Building Permit (BP) for any construction hoarding. If construction hoarding is required to temporarily occupy a public street, the air space above a public street, or any part thereof, additional City approvals and associated fees may be required as part of the Building Permit. For additional information, contact the Building Approvals Department at 604-276-4285.

**At Subdivision\* stage, the applicant must complete the following requirements:**

1. Complete the following servicing works and off-site improvements. These may be completed through a Servicing Agreement\* or a City work order:

*Water Works:*

- Using the OCP Model, there is 260 L/s of water available at a 20 psi residual at the Heather Street frontage. Based on your proposed development, your site requires a minimum fire flow of 95 L/s.
- The Developer is required to:

Initial: \_\_\_\_\_

- Submit Fire Underwriter Survey (FUS) or International Organization for Standardization (ISO) fire flow calculations to confirm the development has adequate fire flow for onsite fire protection. Calculations must be signed and sealed by a Professional Engineer and be based on Building Permit Stage Building designs.
- At Developer's cost, the City is to:
  - Cut and cap, at main, existing water service connection.
  - Install 2 new water service connections, complete with meter and meter box, off of the existing 150 mm water main along the west property line.

*Storm Sewer Works:*

- The Developer is required to:
  - Retain the existing storm service connection at the northeast corner of the lot.
- At Developer's cost, the City is to:
  - Install a new storm service connection, complete with inspection chamber, off of the existing 450 mm storm sewer along the west property line.

*Sanitary Sewer Works:*

- The Developer is required to:
  - Not start onsite foundation construction prior to completion of rear yard sanitary works by City crews.
- At Developer's cost, the City is to:
  - Install 2 new sanitary service connections, complete with inspection chambers, off of the existing 250 mm PVC sanitary sewer main along the west property line.
  - Cut, cap, and remove, at main, existing sanitary service connection and inspection chamber SIC15280 at southeast corner of the subject site.

*Frontage Improvements:*

- The Developer is required to:
  - Coordinate with BC Hydro to underground Hydro service lines.
  - Coordinate with BC Hydro, Telus and other private communication service providers
    - When relocating/modifying any of the existing power poles and/or guy wires within the property frontages.
    - To determine if above ground structures are required and coordinate their locations (e.g. Vista, PMT, LPT, Shaw cabinets, Telus Kiosks, etc.). These should be located onsite.
  - Pay, in keeping with the Subdivision and Development Bylaw No. 8751, a \$22,679.60 cash-in-lieu contribution for the design and construction of frontage upgrades as set out below:

● Concrete Curb and Gutter (EP.0641)	\$3,658.00
● Concrete Sidewalk (EP.0642)	\$5,304.10
● Pavement Widening (EP.0643)	\$6,401.50
● Roadway Lighting (EP.0644)	\$2,011.90
● Boulevard Landscape/Trees (EP.0647)	\$5,304.10

*General Items:*

- The Developer is required to:
  - Enter into, if required, additional legal agreements, as determined via the subject development's Servicing Agreement(s) and/or Development Permit(s), and/or Building Permit(s) to the satisfaction of the Director of Engineering, including, but not limited to, site investigation, testing, monitoring, site preparation, de-watering, drilling, underpinning, anchoring, shoring, piling, pre-loading, ground densification or other

Initial: \_\_\_\_\_



activities that may result in settlement, displacement, subsidence, damage or nuisance to City and private utility infrastructure.

**Note:**

- \* This requires a separate application.
- Where the Director of Development deems appropriate, the preceding agreements are to be drawn not only as personal covenants of the property owner but also as covenants pursuant to Section 219 of the Land Title Act.

All agreements to be registered in the Land Title Office shall have priority over all such liens, charges and encumbrances as is considered advisable by the Director of Development. All agreements to be registered in the Land Title Office shall, unless the Director of Development determines otherwise, be fully registered in the Land Title Office prior to enactment of the appropriate bylaw.

The preceding agreements shall provide security to the City including indemnities, warranties, equitable/rent charges, letters of credit and withholding permits, as deemed necessary or advisable by the Director of Development. All agreements shall be in a form and content satisfactory to the Director of Development.

- Additional legal agreements, as determined via the subject development's Servicing Agreement(s) and/or Development Permit(s), and/or Building Permit(s) to the satisfaction of the Director of Engineering may be required including, but not limited to, site investigation, testing, monitoring, site preparation, de-watering, drilling, underpinning, anchoring, shoring, piling, pre-loading, ground densification or other activities that may result in settlement, displacement, subsidence, damage or nuisance to City and private utility infrastructure.
- Applicants for all City Permits are required to comply at all times with the conditions of the Provincial *Wildlife Act* and Federal *Migratory Birds Convention Act*, which contain prohibitions on the removal or disturbance of both birds and their nests. Issuance of Municipal permits does not give an individual authority to contravene these legislations. The City of Richmond recommends that where significant trees or vegetation exists on site, the services of a Qualified Environmental Professional (QEP) be secured to perform a survey and ensure that development activities are in compliance with all relevant legislation.

---

Signed

---

Date



Richmond Zoning Bylaw 8500
Amendment Bylaw 9623 (RZ 16-737446)
8140 Heather Street

The Council of the City of Richmond, in open meeting assembled, enacts as follows:

- 1. The Zoning Map of the City of Richmond, which accompanies and forms part of Richmond Zoning Bylaw 8500, is amended by repealing the existing zoning designation of the following area and by designating it "SINGLE DETACHED (RS2/A)".

P.I.D. 002-551-381

Lot 556 Section 22 Block 4 North Range 6 West New Westminster District Plan 60575

- 2. This Bylaw may be cited as "Richmond Zoning Bylaw 8500, Amendment Bylaw 9623".

FIRST READING

A PUBLIC HEARING WAS HELD ON

SECOND READING

THIRD READING

OTHER CONDITIONS SATISFIED

ADOPTED

Series of horizontal lines for recording readings and conditions.

CITY OF RICHMOND APPROVED by BK APPROVED by Director or Solicitor [Signature]

MAYOR

CORPORATE OFFICER