

ThinkLink

Danger Ahead for GVRD Taxpayers and Transit Users

*Cost and Tax Implications of the
ThinkLink Three-Year Financial Plan*

ThinkLink

KEY MESSAGES

- Financial plan is inadequate
- Who gets hit - regional taxpayers and transit users
- This Plan is not responsible government
- We asking you to join us in urging your Council to instruct the GVRD Board to reject the TransLink Plan and request it prepare an alternative that better safeguards the interests of all regional taxpayers and transit users.

TransLink's Ten-Year Plan (Wish List)

- Replace 1,300 vehicles (\$600 m)
- Start replacement of SkyTrain Mark I vehicles with Mark II's (\$300m)
- Expand bus, Community Shuttle, and HandyDART fleet (\$200m)
- WCE – new stations and spare locomotive (\$10m)
- Transit maintenance and infrastructure (\$500 m)
- Bike Program* (\$54 m)/
- SmartCard/other ITS applications (\$20m)
- expand service on existing SkyTrain lines (\$200m)
- New SeaBus (\$10m)
- RAV and NES rapid transit lines, and King George Busway (GVTA contribution - \$800m)
- Roads – Major Projects (\$400m) Minor Projects and Bridges (\$25 m)
- Fraser River Crossing (\$600m – recovered by tolls)

10-Year Outlook - 3-Year Plan

Translink Expenditures and Revenues

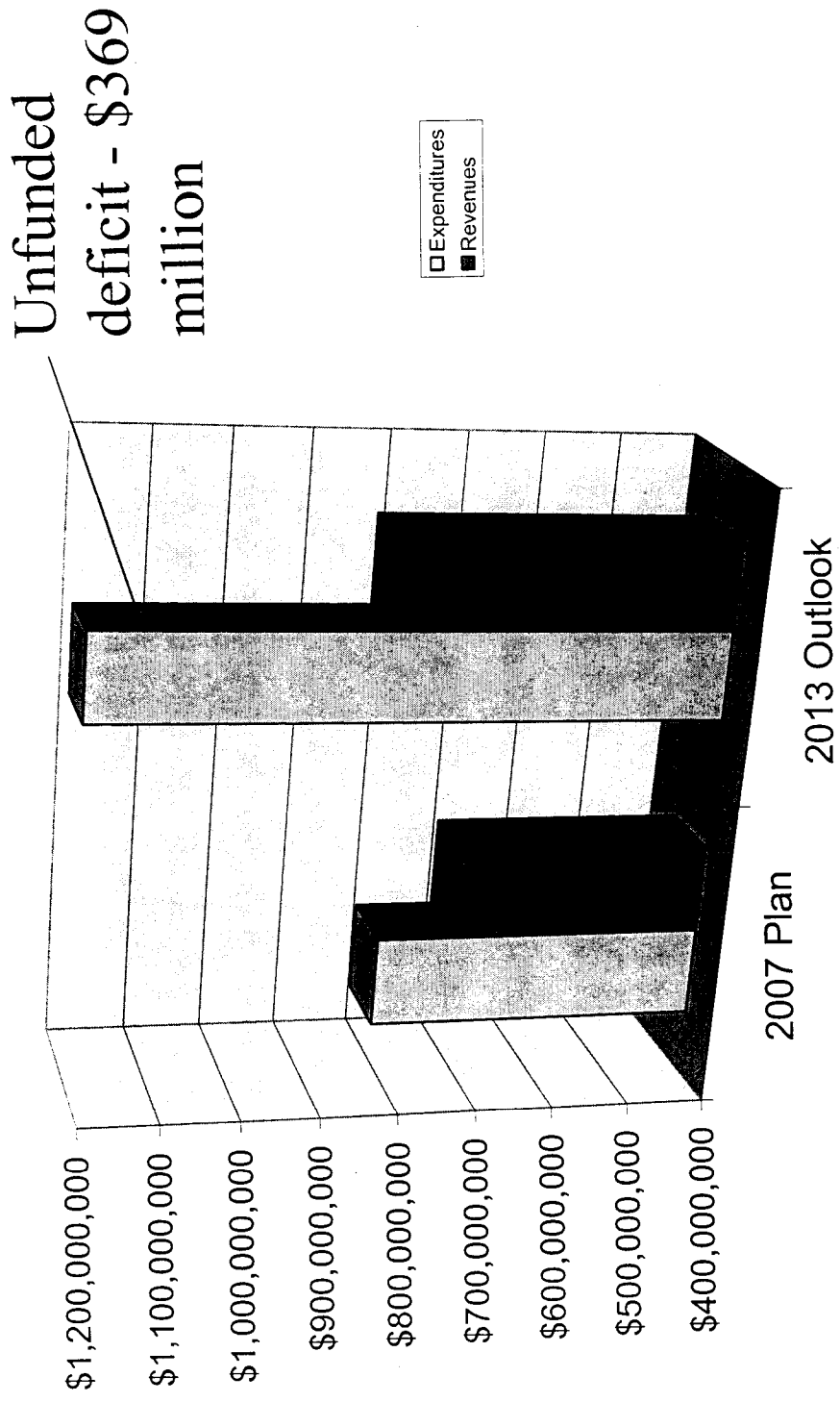

Source: GVTA Consolidated Statement of operations and Three-year Plan and 10-Year Outlook - December 3, 2003

TransLink Revenue Base Already Expanding Exponentially

2002 Increases

- Fares (\$15-20 million/yr)
- gas tax (\$40 million/yr)
- property tax (\$20 million/yr or \$22 on average home)

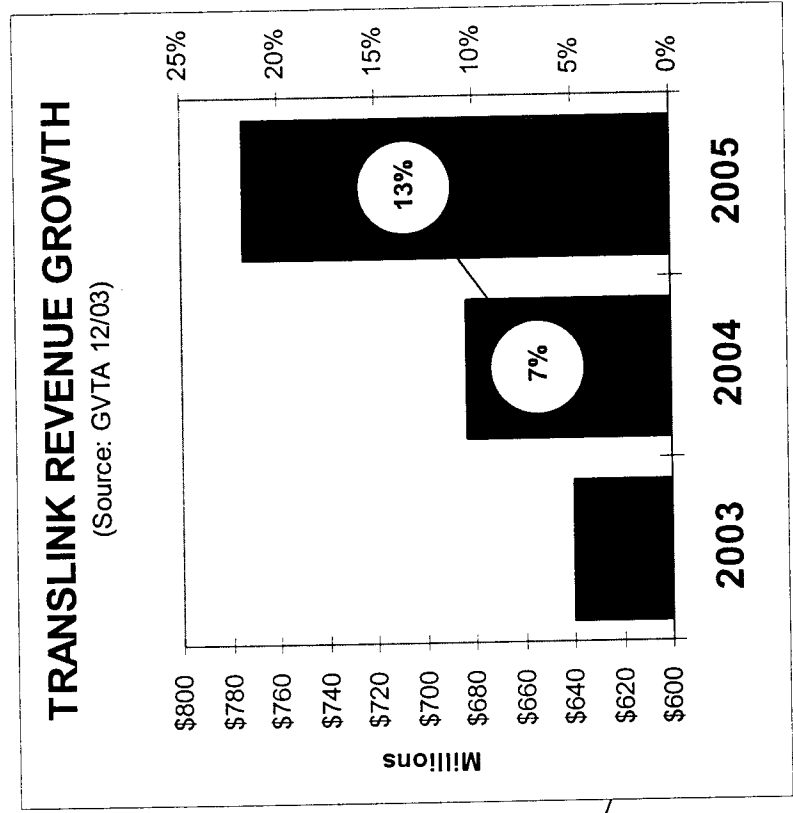

Continued Increases for Transit Users

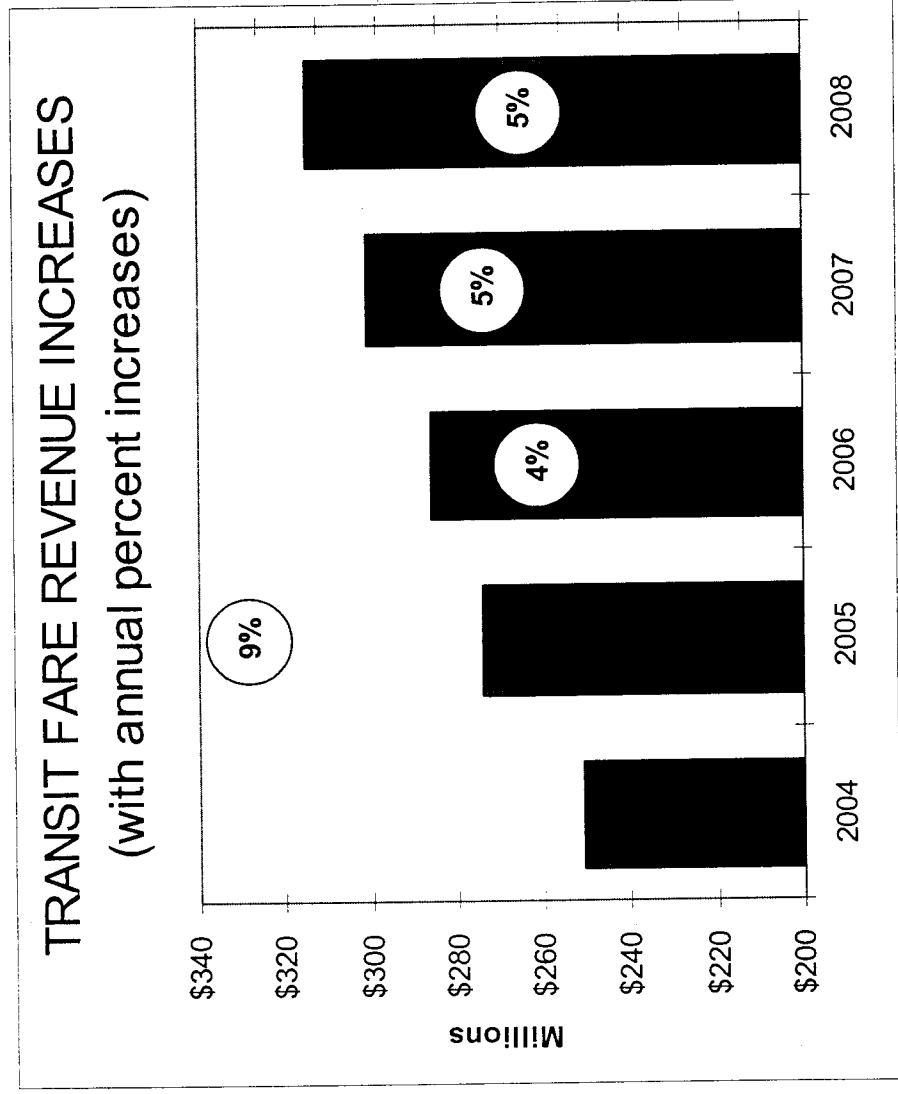

Source: GVTA Consolidated Statement of operations and Three-year Plan and 10-Year Outlook - December 3, 2003

Transit Revenue Grows From Taxation: 2000-2005

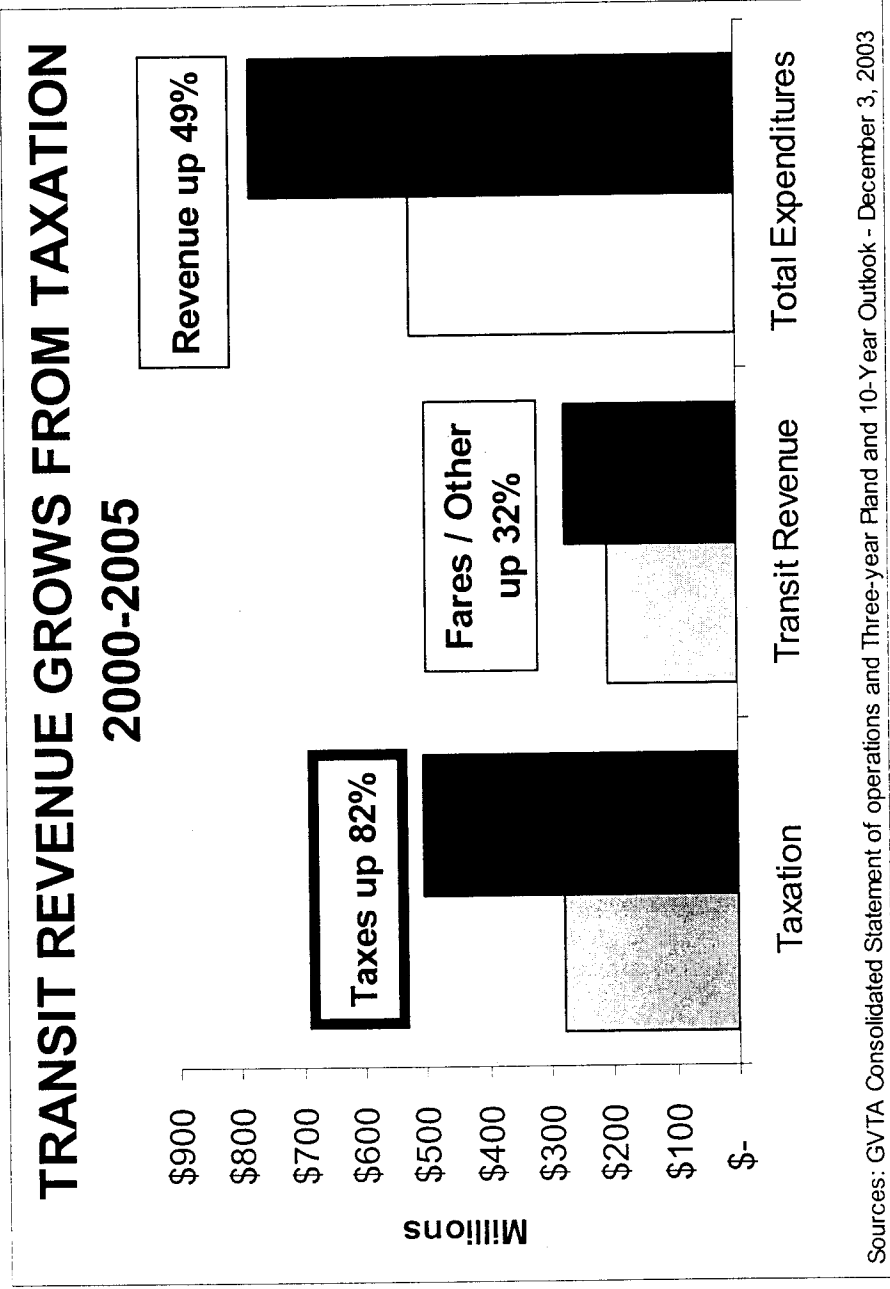

Taxation Proportion Grows

(Share of Annual TransLink Revenue 2000 Actual and 2005 Proposed)

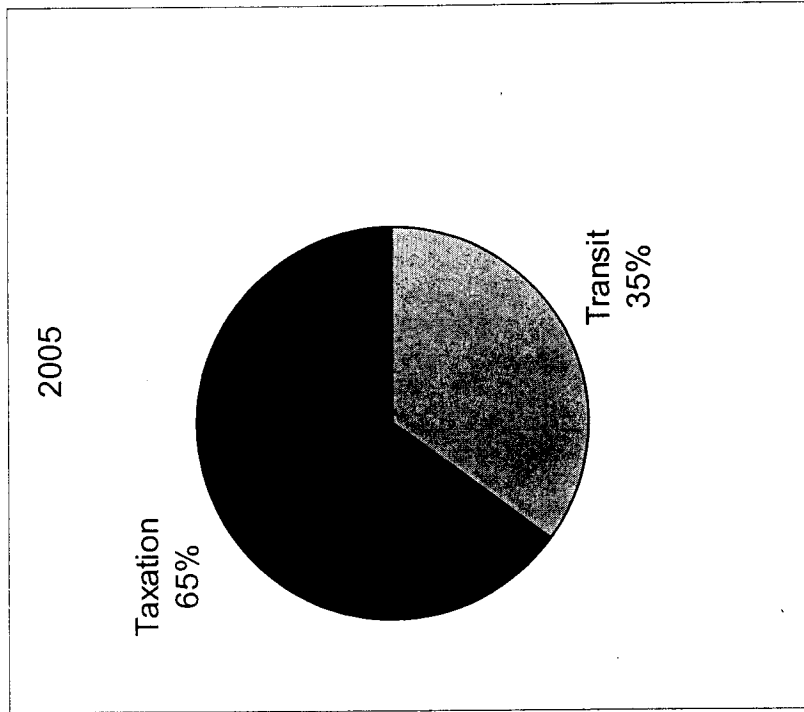
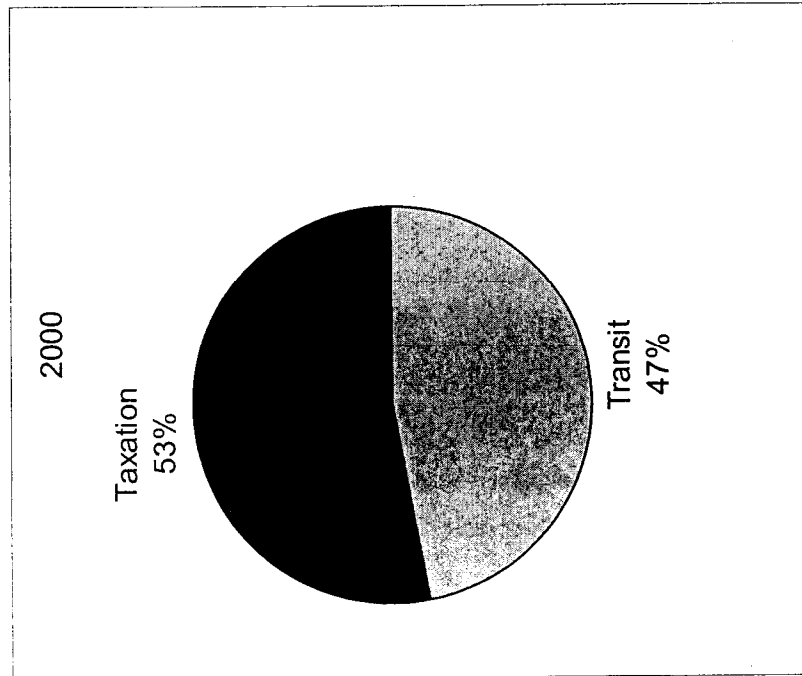

Residential Taxes are High and Will Continue to Grow

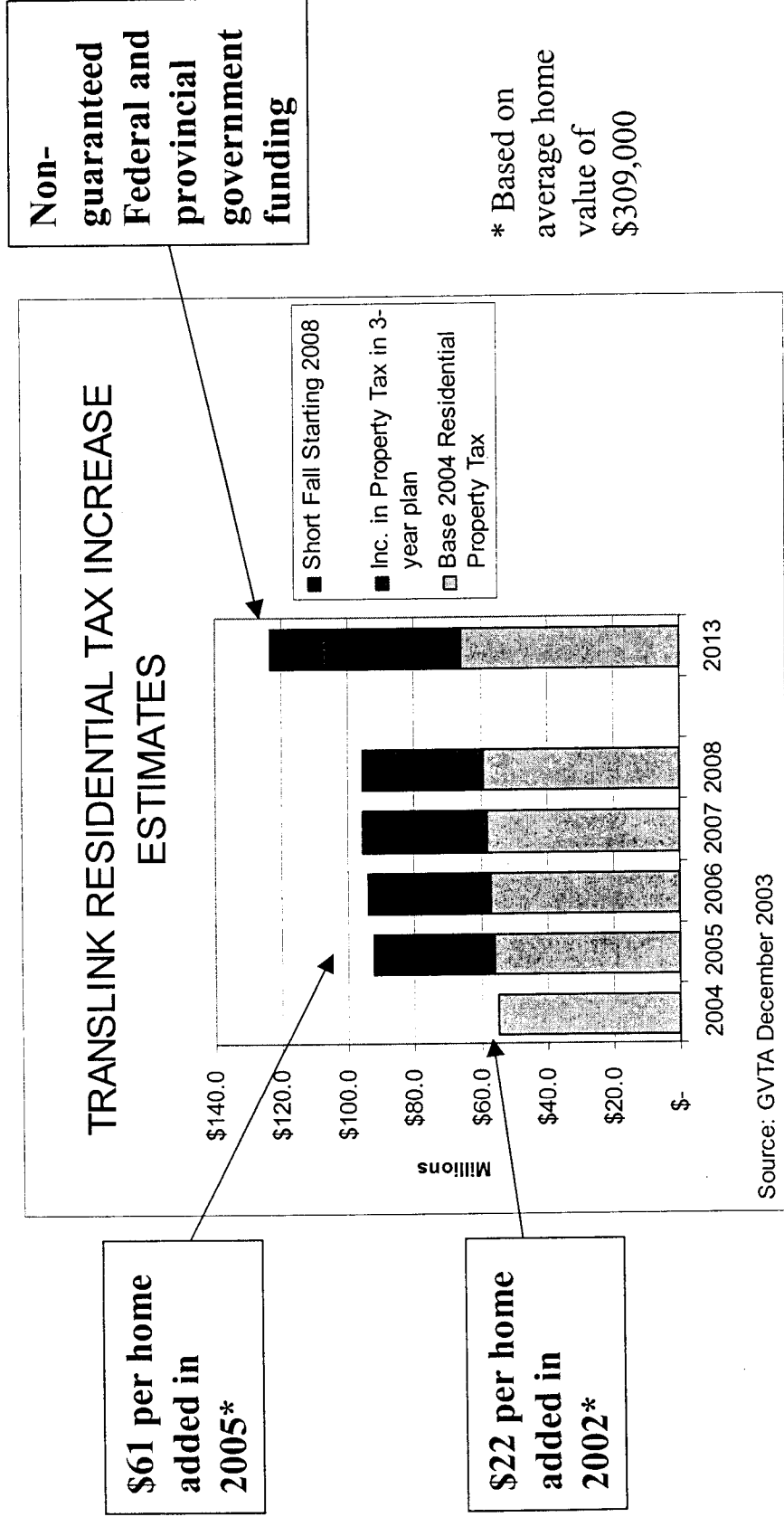

Business Costs will Rise

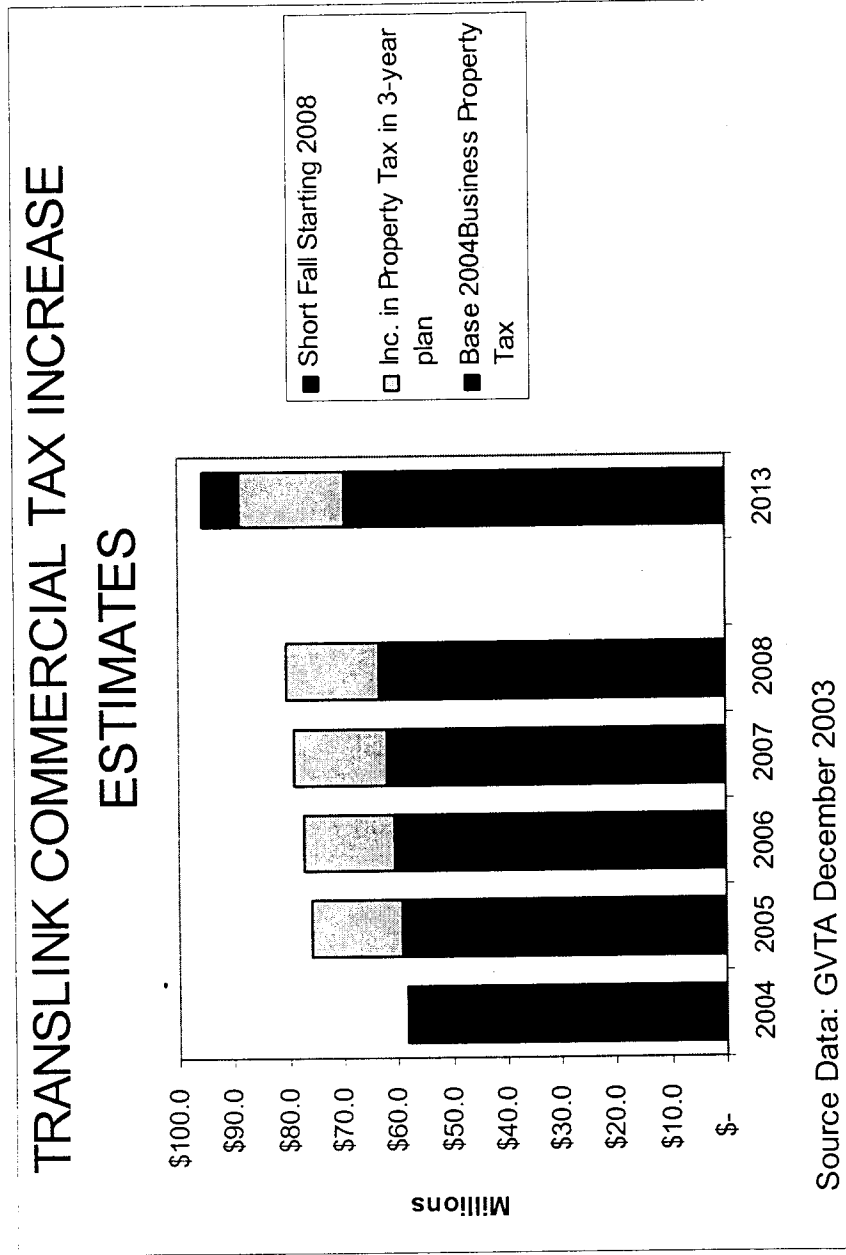

Parking Taxes will Further Increase Business Costs

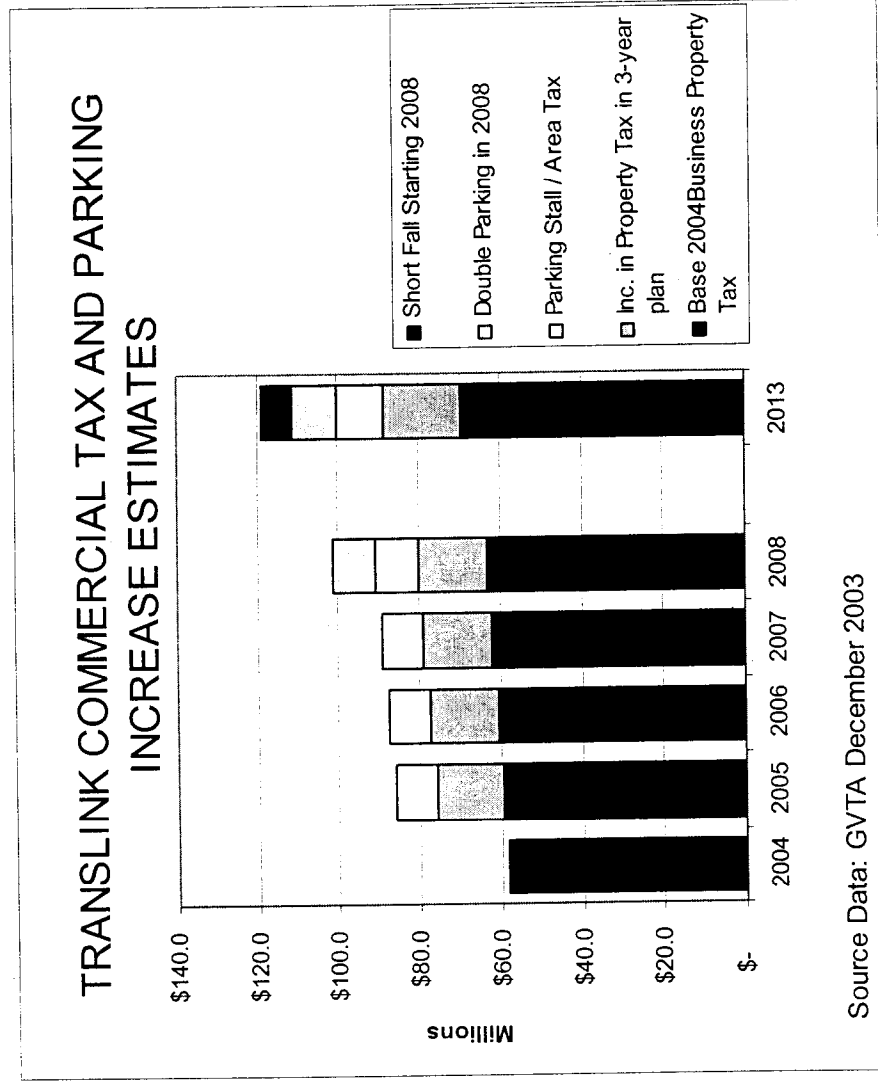

Source: GVTA Consolidated Statement of operations and Three-year Plan and 10-Year Outlook - December 3, 2003

Cost Over-runs Increase Taxpayer Liability

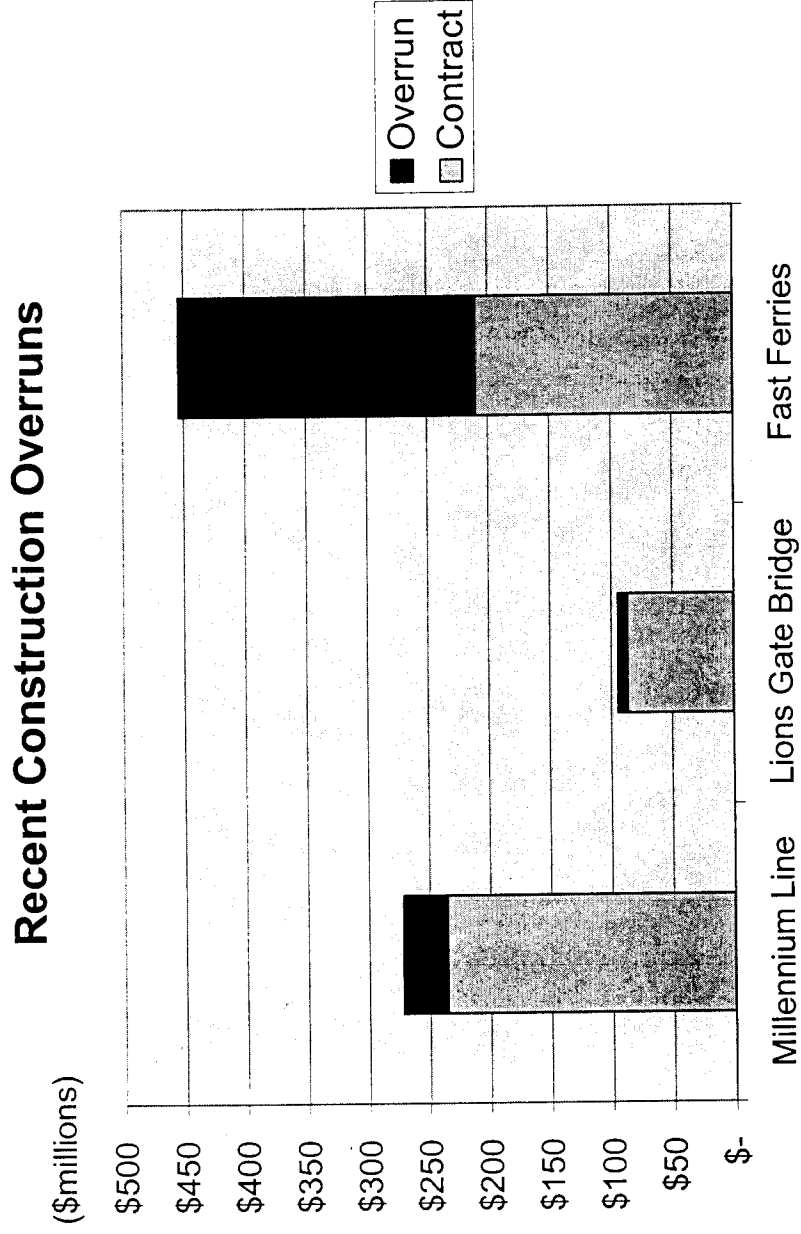

Source: Canadian Centre for Policy Alternatives, 2003

TransLink Competes With Municipalities

Share of Non-School Residential Taxes 2003

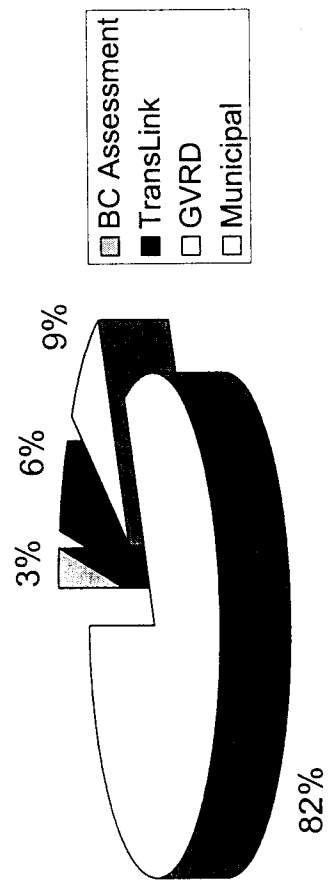

Share of Non-School Residential Taxes 2008

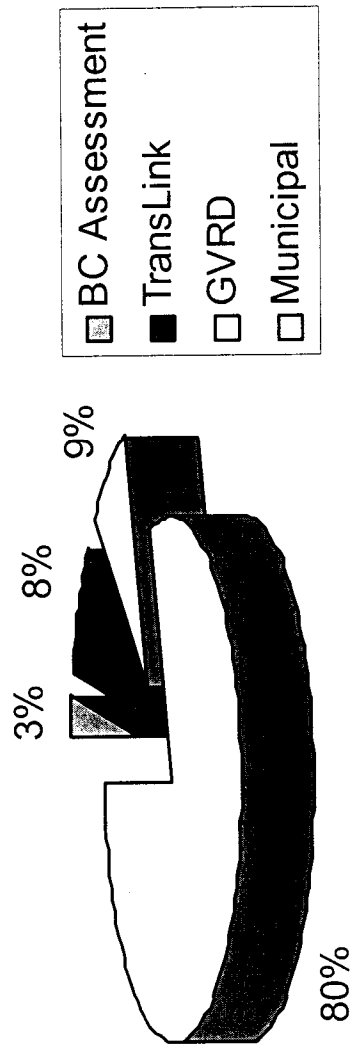

POTENTIAL RESIDENTIAL PROPERTY TAX INCREASES*
 REQUIRED TO MEET
 THE \$369 MILLION SHORTFALL IN 2013
 IN TRANSLINK'S 10 YEAR OUTLOOK

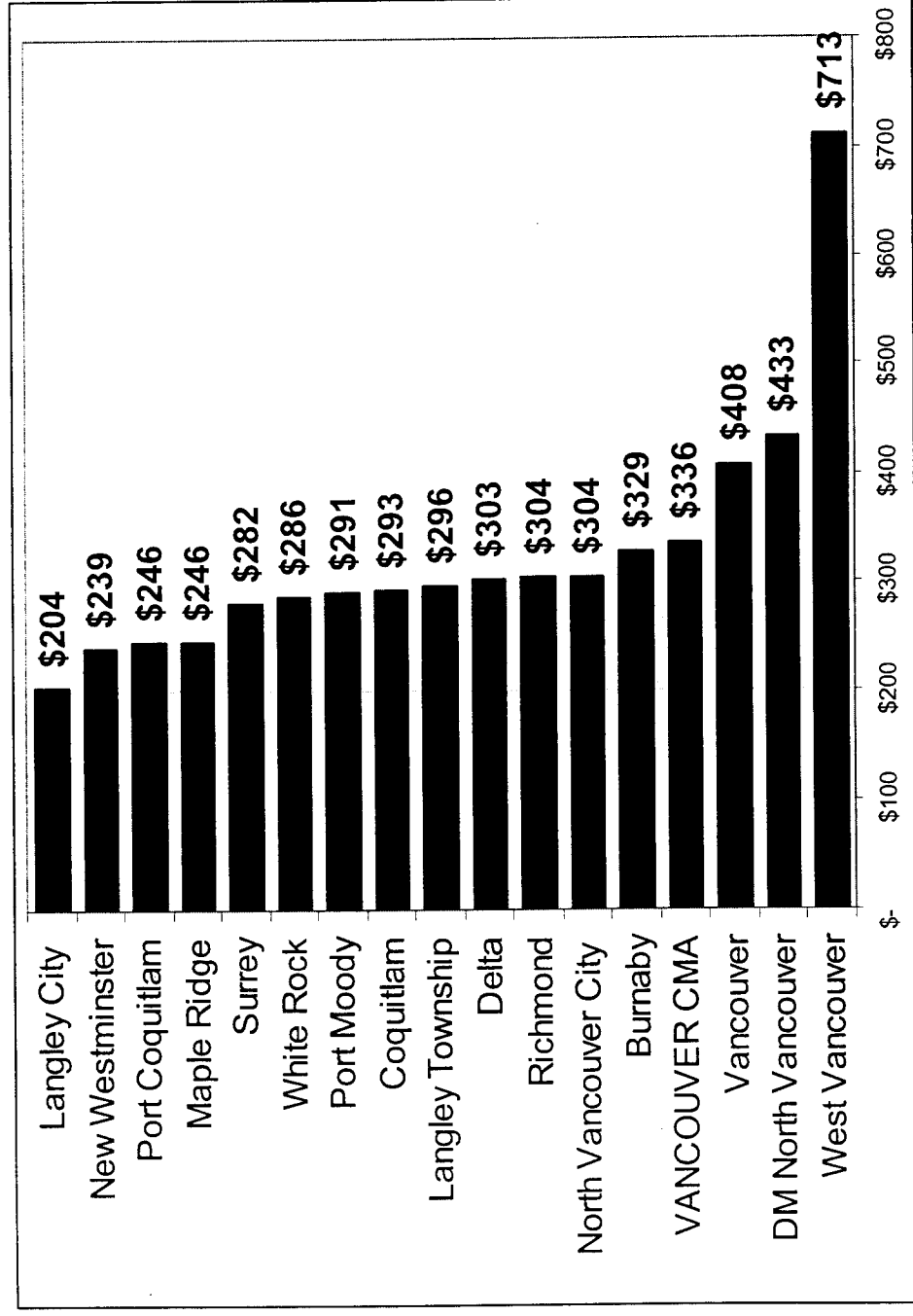

* EXPRESSED IN 2005 DOLLARS

Conclusion

- Financial plan is inadequate
- Who gets hit - regional taxpayers and transit users
- This Plan is not responsible government
- We asking you to join us in urging your Council to instruct the GVRD Board to reject the TransLink Plan and request it prepare an alternative that better safeguards the interests of all regional taxpayers and transit users.

Think Link

A coalition for responsibly financed transportation

For immediate release

TransLink Plan Financially Flawed **GVRD staff/committee actions confirm coalition's concerns**

Vancouver, B.C. (February 16, 2004) – The GVRD request that TransLink resolve outstanding funding issues confirms its transportation plan is financially flawed, according to ThinkLink, a coalition of business interests in the Lower Mainland.

"We don't think governments should propose or approve multi-billion dollar spending programs without detailed financing plans that clearly show taxpayers what to expect and that it's affordable," said Ted Williams, ThinkLink Co-Chair.

"GVRD's Finance Committee is obviously concerned. A staff report issued earlier also raised concerns about the lack of identified funding, recommending approval of the plan be deferred until the shortfall is resolved. The message is pretty clear: the GVRD Board should send this plan back to TransLink."

Williams noted that, according to TransLink's financial plan, TransLink is projecting a deficit of \$369 million a year by 2013 with no identified funding to cover it. "This is an unacceptable level of exposure," said Williams. "And let's face it, property taxpayers and transit users will end up footing the bill, one way or the other, for ambitious plans that are not responsibly and transparently financed from the outset."

ThinkLink is also concerned that the GVRD Finance Committee is expecting the outstanding financial issues to be resolved in just two weeks so that the plan can go to a vote of the GVRD Board on February 27.

"Suggesting that the lack of detail regarding specific funding sources and project costs can be resolved in less than two weeks without consulting the public is not only unfair, it is absurd," said Williams. "The members of ThinkLink are trying to get that message out to the public because, frankly, someone sure needs to."

"Once the public is aware of the financial risks involved, we're going to see a groundswell of opposition. We all know that the region needs to improve its transportation infrastructure, but we don't need another 'fast ferry' debacle where the public ends up paying because politicians are in a hurry to spend money they don't have."

- more -

ThinkLink is a coalition for responsibly financed transportation. Its members are in favour of improving the transportation system, but are opposed to multi-billion dollar plans that are not responsibly financed. ThinkLink members include boards of trade, industry associations and private sector companies.

- 30 -

For more information, please contact:

Jennifer Davies, Contemporary Communications
604-637-3045

February 13, 2004

Attention: Richard McKenna, City Clerk, City of Richmond

Facsimile: 604278-5139

		INT
	JM	
✓	DW	DW
	KY	
	AS	
	DB	
	WB	
✓	PA	

0154-04

We request to appear before council as a delegation to speak to the issue of the TransLink 10-year Financing plan.

Our speaker will be Peggy White who will require 10 minutes for the presentation.

We have a Power Point presentation and would like to use it. Please advise if we need to bring our own laptop, use your laptop, and whether or not we can email the presentation for mounting on your system? If we cannot email, for your computer, do we need a 3 1/2" diskette, or a CD?

It is most important that our presentation be heard on or before February 23rd.

Please reply at your earliest convenience to advise us of the time of our presentation.

If replying by phone, please call Anthony Toth at (604) 340-5017 or via fax at 604-925-0931.

Regards,

S. Anthony Toth
ThinkLink



Ashton, Fran

From: S. Anthony Toth [tt500@shaw.ca]
Sent: February 16, 2004 11:25 PM
To: Ashton, Fran
Cc: Clarke, Lorelee; Andrew Pottinger
Subject: Richmond Council ThinkLink presentation

Fran Ashton:

Thank you for confirming the ThinkLink presentation to Richmond Council on February 23rd, 2004. Our speaker will be Peggy White and she will speak for 5 minutes plus questions. She will be placed at the end of the agenda and we will check with you on Friday the 19th (604-276-4163) to determine what time that might be.

I enclose her Power Point presentation as well as a press relase about ThinkLink.

Thank you for your assistance.

Regards, Tony T.

S. Anthony Toth
#201 - 2243 Folkestone Way
West Vancouver, BC V7S 2Y7
Phone: 604-925-5291
Fax: 604-925-0931
Email: tt500@shaw.ca